

APPLICATIONS

Architecturally styled heavy duty fan heaters for commercial areas. Rugged construction without the 'industrial' look make the CHDA an ideal choice for entrance lobbies, stairways and waiting rooms. Higher capacities, up to 5kW, for larger area heating requirements. The integral tamper proof thermostat provides efficient energy control at low installation cost.

FEATURES

- Suitable for surface or space saving recess mounting
- High reliability heavy duty finned metal sheathed elements
- Totally enclosed permanently lubricated motor
- Manual reset over temperature safety cut-out
- Integral thermostat that can be tamper proof
- Heavy duty welded steel louvred grille with aluminium frame
- Quiet low speed axial fan
- Dark brown powder coated finish with anodised natural aluminium frame
- London underground approved (when modified)



INSTALLATION

The units are for vertical mounting only, not less than 300mm from any vertical surface or the floor. Each unit is supplied for recess mounting, surface mounting requires the optional surface box (CHDA-S). The unit should be securely fixed.

All electrical connections should be made by a suitably qualified person in accordance with the latest edition of the IEE Requirements for Electrical Installation (BS 7671:2008).

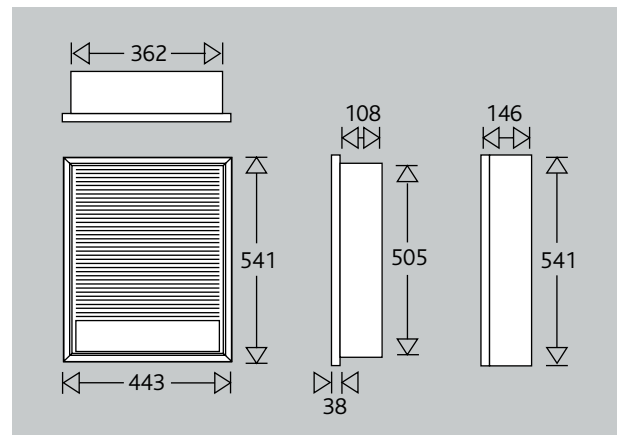

CAT No.	Application Type	kW	Volts	Air Vol (m3/hr)	Length (mm)	Height (mm)	Depth (mm)	Weight (kgs)	Trade Price
CHDA-2000	For recess mounting	2	230	340	541	443	146	12	£645
CHDA-3000	For recess mounting	3	230	340	541	443	146	12	£685
CHDA-4000	For recess mounting	4	230	340	541	443	146	12	£730
CHDA-5000	For recess mounting	5	230	340	541	443	146	12	£740
CHDA-S	Surface mounting box				541	443	146	1	£60