

Installation Instructions

The RCHB-3210-TT Ceiling heater for surface mounting

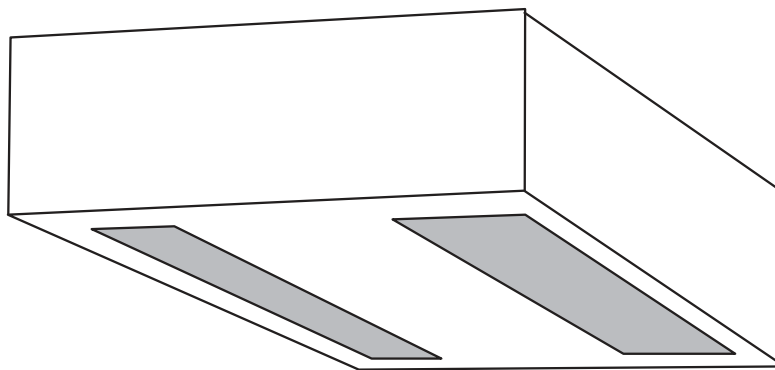

*with **integral relays** to allow connections
of Time clock and thermostat*

Please retain for future reference

SAFETY

The correct procedures for working at height must be adopted when installing this heater.

The heater must be installed by a suitably qualified person in accordance with current regulations.

CONTENTS

Remove from carton and check contents ;

- heater unit
- (Time clock and thermostat not supplied)

LOCATION

The heater must be installed at a minimum of 2 m and a maximum of 3m from the floor.

The heater can be positioned in the corner of a ceiling but for better heat distribution at least 600mm from each wall is preferable.

The unit should not be positioned over desks, counters or high level display racking wherever a constant flow of heated air may be uncomfortable or cause overheating of equipment.

CONTROL

FAN OUTPUT

The main relay (Terminals T1 and T2) controls the supply to the unit. This has to be switched by a fused 230V supply connection unit incorporating either a time switch / programmer for automatic control (CTTF) or an on/off switch for manual control. The fan runs continuously when the relay is switched on.

HEAT OUTPUT

The second relay controls the switching of the heating elements, they are not switched individually.

TEMPERATURE

The second relay (Terminals T3 and T4) is also switched by a fused 230V supply, usually the temperature controlled circuit. A single thermostat (CRST-16) can control all the heaters. Alternatively several can be used to create zones thus compensating for uneven heat requirements.

The thermostats should be mounted out of the direct influence of the heated airflow.

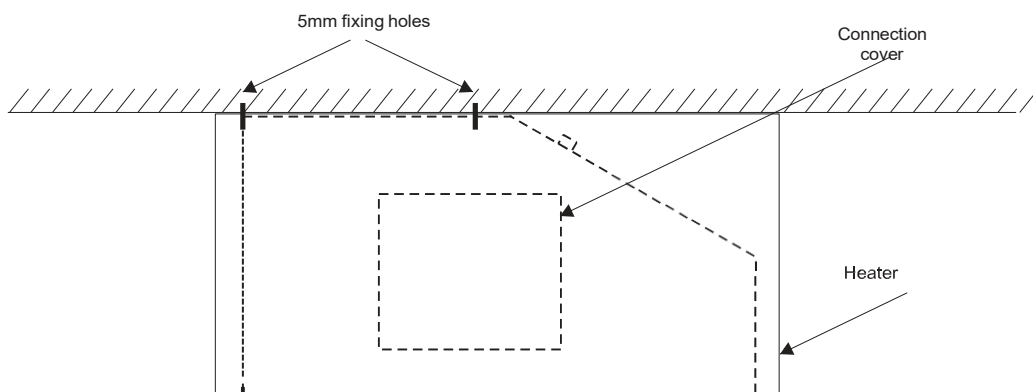

FIXING

This heater is designed for surface installation to any ceiling that can adequately support the unit. The unit weighs 9kgs.

Remove the front cover of the unit

Fixings are made through the top flat section of the heater body using the 4 No 5mm holes provided. This section must be flat on the ceiling as the edges of the cover are designed to fit against the ceiling.

Securely fix the heater and make off the electrical connections taking into account the routing of cables in relation to the cover. Ensure fixings and cables are clear of moving parts and the heater elements.

Re fix the cover ensuring the fan outlet is adjacent to the smaller outlet grille.

ELECTRICAL CONNECTION

The heater should be installed in accordance with the latest edition of the IEE Requirements for Electrical Installation (BS 7671) by a suitably qualified person.

Remove tile adjacent to connection cover plate. Remove non captive screw from side connection cover and swivel to side. Position heater in ceiling (See Fixing)

A means of disconnection having a contact separation of 3mm in all poles should be incorporated in the power supply.

Select power cabling of appropriate size for current and volt drop for the heater.

Select control cabling with 4 cores and earth of appropriate size for current and volt drop (Control/motor circuit power consumption approx 50W per unit)

Pass cable/s through cord grip in top of unit. Leave sufficient length for connection but ensuring cables do not foul blower unit. Make off connections to connector block and earth stud in accordance with circuit diagram RCH-W-012 (copy on back page and on top of unit)

Tighten up cord grip. Replace connection cover plate. Replace heater cover.

IMPORTANT : always check to ensure the heating elements cannot be energised without the fan running.

WARNING THE HEATER MUST BE EARTHED

OVER TEMPERATURE CUT OUT

Should the heater exceed normal operating temperature the over temperature cut out on the heating elements will operate. The fan will continue to run.

To RESET - switch off power to the unit and allow to cool before switching on again. If the problem persists consult a suitably qualified person.

MAINTENANCE

Isolate the heater and remove any build up of dust etc. every 6 months. Check that the heater has not been covered or the airflow restricted in any way.

WARRANTY

This product is guaranteed, in accordance with our Conditions of Sale, for a period of 12 months from date of purchase. We will repair or replace, at our discretion, any part found to be defective. We cannot accept responsibility for any consequential liability.

The warranty will be invalid if the heater has not been installed in accordance with these instructions.

This does not affect your statutory rights.

The manufacturers reserve the right to change the specification at any time without prior notice EO&E



Turnbull & Scott Group
Burnfoot Industrial Estate,
Hawick, Roxburghshire,
Scotland, TD9 8SL
www.Turnbull-scott.co.uk
info@turnbull-scott.co.uk
01450 372053

Warning
Multiple supply isolate ALL before opening connection cover.

Relay coil 1(T1T2) to be energised by 230V from timer on/off controlled and fused supply
Relay coil 2(T3T4) to be energised by 230V from thermostat controlled and fused supply

Heating element incorporates over temperature cut out.
Fan continues to run if cut out operates.

To reset:
Switch off and allow to cool (5 minutes) then restore supply

Heater does not function again until power has been removed from cut out.

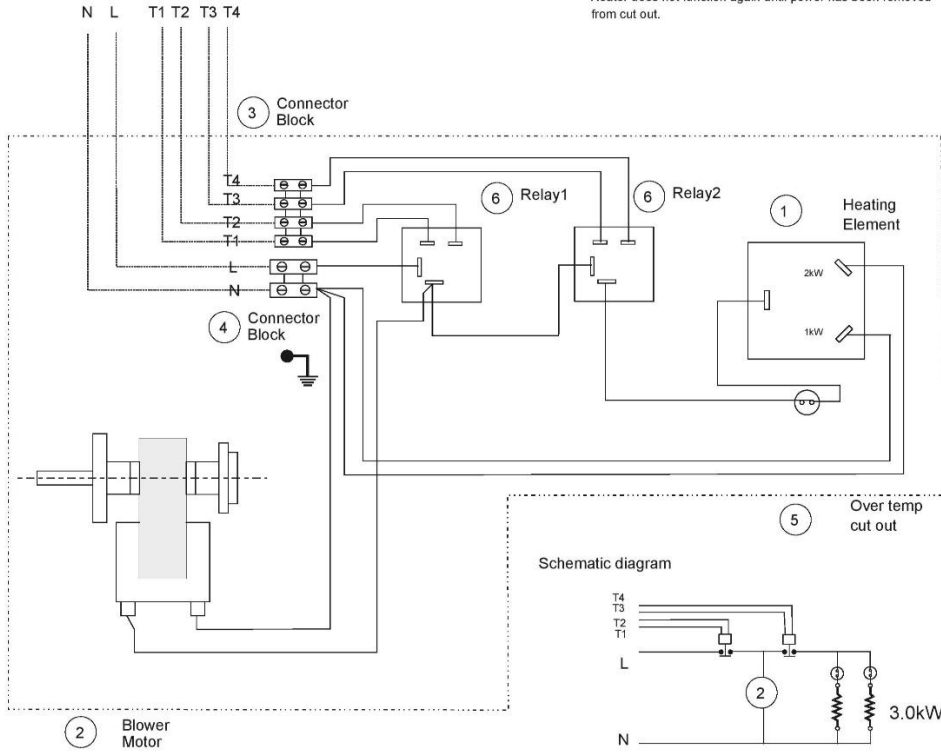

No	Part No	Description
1	B081-01	Heating element
2	C002	Blower/motor
3	F003	16A Con block
4	F036-1	40A Con block
5		Over temp cut outs
6	E128	Relay

No	Revision	Date
1	Change relays	01/11
2	Motor/Fan Change	03/22
3	Relay link wiring change	02/25
4	Connector Block Changed	10/25

Title **RCHS/R/B-3210-TT
Recessed Ceiling Htr
with integral relays**

Drawn by **JS** Date **07/10/25**

Scale Drawing No. Rev
nts RCH-W-012 4

L011

One relay is connected in the incoming live to control the on and off of the heater. A second relay is connected between the first relay and the elements to control the heating elements only.

The fan motor will run continuously when there is power to the heater through relay 1

Each relay is independently switched via a fused power supply controlled by time clock or thermostat

See RCH-W-012 and RCH-W-013 for heater circuit detail

Note: Multiple supply isolate ALL before opening connection cover.

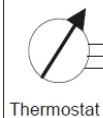

Note
It is necessary to link Terminals 2 and 3 in the CTF unit.

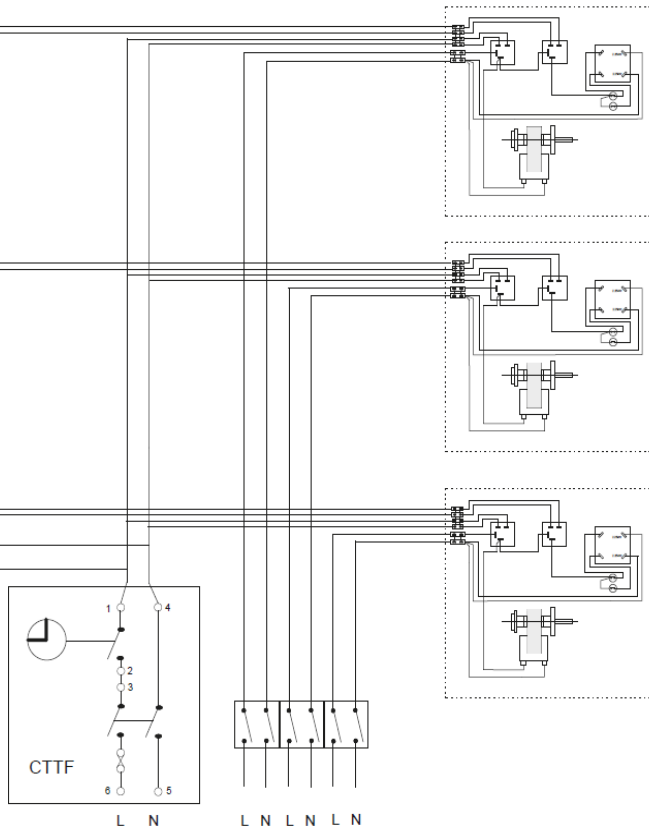

No	Part No	Description
1		
2		
3		
4		
5		
6		
7		

No	Revision	Date
1		
2		

Title **Typical site connection
RCHX-xxxx TT with CTF
Recessed Ceiling Htr**

Drawn by **NEB** Date **30.08.07**

Scale Drawing No. Rev
nts RCH-W-014A 0

L011

Installation Instructions

The RCHB 4200 Ceiling heater for surface mounting

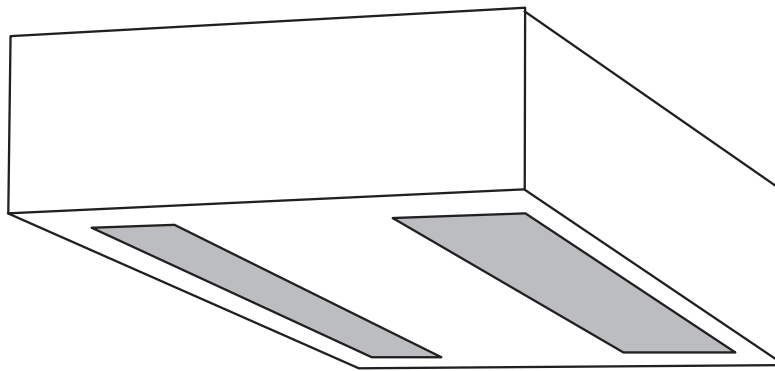

Complete with **REMOTE SWITCH UNIT**
for Fan only, 4.5 and 2.25kW

Please retain for future reference

SAFETY

The correct procedures for working at height must be adopted when installing this heater.

The heater must be installed by a suitably qualified person in accordance with current regulations.

CONTENTS

Remove from carton and check contents ;

- heater unit
- ODH-RSW three switch control unit

LOCATION

The heater must be installed at a minimum of 2 m and a maximum of 3m from the floor.

The heater can be positioned in the corner of a ceiling but for better heat distribution at least 600mm from each wall is preferable.

The unit should not be positioned over desks, counters or high level display racking wherever a constant flow of heated air may be uncomfortable or cause overheating of equipment.

If required the unit can be covered with non flammable insulating material to maintain the integrity of the ceiling insulation.

CONTROL

Remote Switch

The Remote Switching Unit allows ON/OFF, Fan only with 2.25 or 4.5 kW.

Thermostat

A thermostat of 25A rating can be connected in the power supply to the Remote switch thus switching the unit off totally when set temperature is reached. Alternatively a thermostat and contactor can be used.

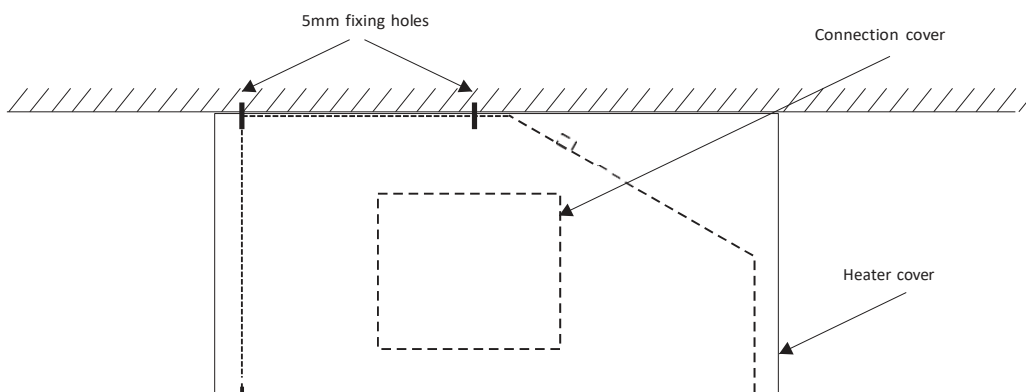

FIXING

This heater is designed for surface installation to any ceiling that can adequately support the unit. The unit weighs 9kgs.

Remove the front cover of the unit

Fixings are made through the top flat section of the heater body using the 4 No 5mm holes provided. This section must be flat on the ceiling as the edges of the cover are designed to fit against the ceiling.

Securely fix the heater and make off the electrical connections taking into account the routing of cables in relation to the cover. Ensure fixings and cables are clear of moving parts and the heater elements.

Re fix the cover ensuring the fan outlet is adjacent to the smaller outlet grille.

ELECTRICAL CONNECTION

The heater should be installed in accordance with the latest edition of the IEE Requirements for Electrical Installation (BS 7671) by a suitably qualified person.

Position heater in ceiling (See Fixing

Remove side connection cover (2 set screws)

Position remote switch unit in suitable location

A means of disconnection having a contact separation of 3mm in all poles should be incorporated..

Select cabling with 4 cores and earth of appropriate size for current and volt drop.

Pass cable/s through cord grip in top of unit. Leave sufficient length for connection but ensuring cables do not foul blower unit. Make off connections to connector block and earth stud in accordance with circuit diagram RCH-W-007 (copy on back page and on top of unit)

If remote switching is not required connect power supply to L and N and link L,LI and LII with 1.5sqmm cable. Tighten up cord grip. Replace connection cover plate. Replace heater cover.

IMPORTANT : always check to ensure the heating elements cannot be energised without the fan running.

WARNING THE HEATER MUST BE EARTHED

OVER TEMPERATURE CUT OUT

Should the heater exceed normal operating temperature the over temperature cut out on the heating elements will operate.

To RESET - switch off power to the unit and allow to cool before switching on again. If the problem persists consult a suitably qualified person.

MAINTENANCE

Isolate the heater and remove any build up of dust etc. every 6 months. Check that the heater has not been covered or the airflow restricted in any way.

WARRANTY

This product is guaranteed, in accordance with our Conditions of Sale, for a period of 12 months from date of purchase. We will repair or replace, at our discretion, any part found to be defective. We cannot accept responsibility for any consequential liability.

The warranty will be invalid if the heater has not been installed in accordance with these instructions.

This does not affect your statutory rights.

The manufacturers reserve the right to change the specification at any time without prior notice EO&E



Turnbull & Scott Group
Burnfoot Industrial Estate,
Hawick, Roxburghshire,
Scotland, TD9 8SL
www.Turnbull-scott.co.uk
info@turnbull-scott.co.uk
01450 372053

Installation Instructions

The RCHB 4200-TT Ceiling Heater for surface mounting

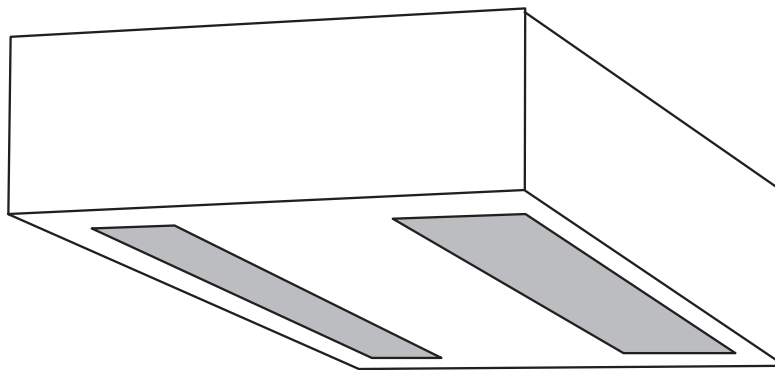

*with integral relays to allow connections
of Time Clock and Thermostat*

Please retain for future reference

SAFETY

The correct procedures for working at height must be adopted when installing this heater.
The heater must be installed by a suitably qualified person in accordance with current regulations.

CONTENTS

Remove from carton and check contents;

- heater unit

(Time clock and thermostat not included)

LOCATION

The heater must be installed at a minimum of 2m and a maximum of 3m from the floor.

The heater can be positioned in the corner of a ceiling but for better heat distribution at least 600mm from each wall is preferable.

The unit should not be positioned over desks, counters or high level display racking wherever a constant flow of heated air may be uncomfortable or cause overheating of equipment.

If required the unit can be covered with non flammable insulating material to maintain the integrity of the ceiling insulation.

CONTROL

FAN OUTPUT

The main relay (Terminals T1 and T2) controls the supply to the unit. This has to be switched by a fused 230V supply connection unit incorporating either a time switch / programmer for automatic control (CTTF) or an on/off switch for manual control. The fan runs continuously when the relay is switched on.

HEAT OUTPUT

The second relay controls the switching of the heating elements, they are not switched individually.

TEMPERATURE

The second relay (Terminals T3 and T4) is also switched by a fused 230V supply, usually the temperature controlled circuit. A single thermostat (CRST-16) can control all the heaters. Alternatively, several can be used to create zones thus compensating for uneven heat requirements.

The thermostats should be mounted out of the direct influence of the heated airflow.

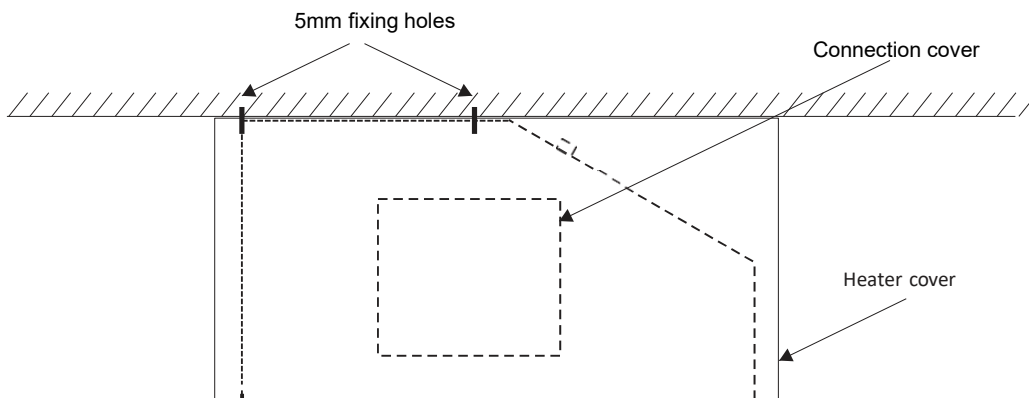

FIXING

This unit is designed for surface installation to ant ceiling that can adequately support the unit. The unit weighs 9kgs.

Remove the front cover of the unit.

Fixings can be made through the top flat section of the heater body using the 4No. 5mmholes provided. This section must be flat on the ceiling as the edges of the cover are designed to fit against the ceiling.

Securely fix the heater and make off the electrical connections taking into account the routing of the cables in relation to the cover. Ensure the fixings and cables are clear of moving parts and the heater elements.

Re fix the cover ensuring the fan outlet is adjacent to the smaller outlet grille.

ELECTRICAL CONNECTION

The heater should be installed in accordance with the latest edition of the IEE Requirements for Electrical Installation (BS 7671) by a suitably qualified person.

Position heater in ceiling (See Fixing).

Remove non captive screw from side connection cover and swivel to side.

A means of disconnection having a contact separation of 3mm in all poles should be incorporated in the power supply.

Select power cabling of appropriate size for current and volt drop for the heater.

Select control cabling with 4 cores and earth of appropriate size for current and volt drop

(Control/motor circuit power consumption approx. 50W per unit)

Pass cable/s through cord grip in top of unit. Leave sufficient length for connection but ensuring cables do not foul blower unit. Make off connections to connector block and earth stud in accordance with circuit diagram RCH-W-013 (copy on back page and on top of unit)

Tighten up cord grip. Replace connection cover plate. Replace heater cover.

IMPORTANT: always check to ensure the heating elements cannot be energised without the fan running.

WARNING THIS HEATER MUST BE EARTHED

OVER TEMPERATURE CUT OUT

Should the heater exceed normal operating temperature the over temperature cut out on the heating elements will operate. The fan will continue to run.

To RESET - switch off power to the unit and allow to cool before switching on again. If the problem persists consult a suitably qualified person.

Maintenance

Isolate the heater and remove any build up of dust etc. every 6 months. Check that the heater has not been covered or the airflow restricted in any way.

Warranty

This product is guaranteed, in accordance with our standard conditions of sale, for a period of 12 months from date of purchase. We will repair or replace, at our discretion, any part found to be defective. We cannot accept any responsibility for any consequent liability.

This warranty will be invalid if the heater has not been installed in accordance with these instructions.

This does not affect your statutory rights.

The manufacturer reserves the right to change the specification at any time without prior notice EO&E



Turnbull & Scott Group
Burnfoot Industrial Estate,
Hawick, Roxburghshire,
Scotland, TD9 8SL
www.Turnbull-scott.co.uk
info@turnbull-scott.co.uk
01450 372053

Warning
Multiple supply isolate ALL before opening connection cover.

Relay coil 1 (T1,T2) to be energised by 230V from timer on/off controlled and fused supply
Relay coil 2 (T3,T4) to be energised by 230V from thermostat controlled and fused supply

Heating element incorporates over temperature cut out.
Fan continues to run if cut out operates.

To reset:
Switch off and allow to cool (5 minutes) then restore supply

Heater does not function again until power has been removed from cut out.

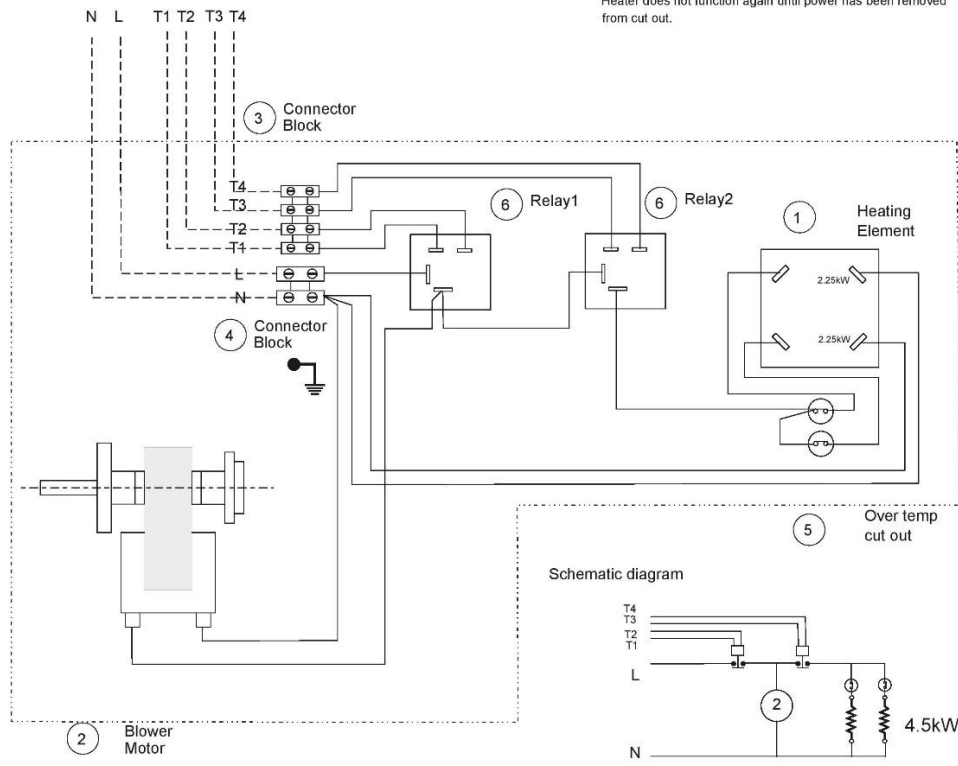

No	Part No	Description
1	B082-01	Heating element
2	C002	Blower/Motor
3	F003	16A Con block
4	F036-1	40A Con block
5		Over temp cut outs
6	E128	Relay

No	Revision	Date
1	Change relays	04/08
2	Motor Blower change	03/22
3	Connector Block Changed	10/25

Title RCHS/R/B-4200-TT
Recessed Ceiling Htr
with integral relays

Drawn by NEB Date 07/10/2025

Scale Drawing No. RCH-W-013 Rev 3

L011

One relay is connected in the incoming live to control the on and off of the heater. A second relay is connected between the first relay and the elements to control the heating elements only.

The fan motor will run continuously when there is power to the heater through relay 1.

Each relay is independently switched via a fused power supply controlled by time clock or thermostat.

See RCH-W-012 and RCH-W-013 for heater circuit detail.

Note: Multiple supply isolate ALL before opening connection cover.

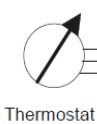

Note: It is necessary to link Terminals 2 and 3 in the CTF unit.

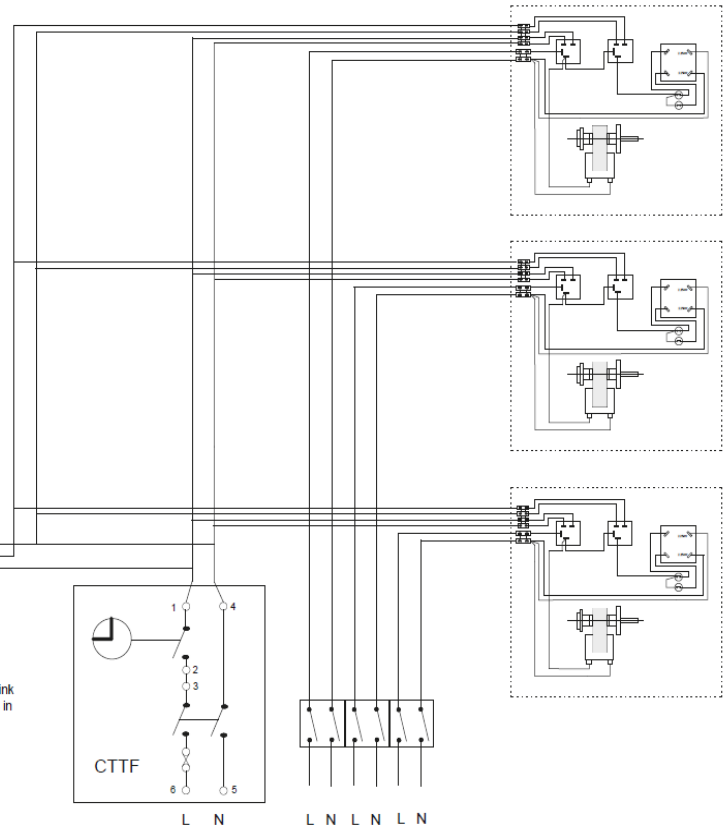

No	Part No	Description
1		
2		
3		
4		
5		
6		
7		

No	Revision	Date
1		
2		

Title Typical site connection
RCHX-xxxx TT with CTF
Recessed Ceiling Htr

Drawn by NEB Date 30.08.07

Scale Drawing No. RCH-W-014A Rev 0

L011

Installation Instructions

The RCHS 3210 for Modular T bar Ceilings

The RCHR 3210 for Plasterboard Ceilings

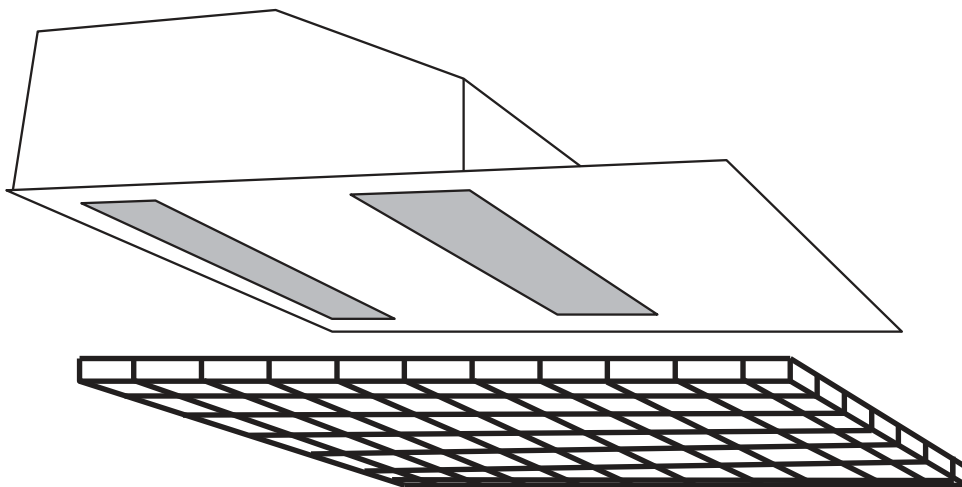

Complete with **REMOTE SWITCH UNIT**
for Fan only, 3, 2 and 1kW

Please retain for future reference

SAFETY

The correct procedures for working at height must be adopted when installing this heater.

The heater must be installed by a suitably qualified person in accordance with current regulations.

CONTENTS

Remove from carton and check contents ;

RCHS-3210

- heater unit
- support clips and 4 no. machine screws
- grille
- ODH-RSW three switch control unit
- 25mm cord grip bush

RCHR-3210

- heater unit
- support clips, 4 no. machine screws and 4 no. woodscrews
- framed grille and 6 no roundhead woodscrews
- ODH-RSW three switch control unit
- 25mm cord grip bush

LOCATION

The heater must be installed at a minimum of 2 m and a maximum of 3m from the floor.

The heater can be positioned in the corner tile of a ceiling but for better heat distribution one tile (600mm) from each wall is preferable.

The unit should not be positioned over desks, counters or high level display racking wherever a constant flow of heated air may be uncomfortable or cause overheating of equipment.

CONTROL

Remote Switch

The Remote Switching Unit allows ON/OFF, Fan only with 1,2 or 3 kW.

Thermostat (CRST16)

A thermostat of 16A rating can be connected in the power supply to the Remote switch thus switching the unit off totally when set temperature is reached.

Alternatively it can be connected inside the switch unit between the Fan switch and heat switches by removing the internal connection. This will control the heating elements only. The fan will run continuously maintaining air circulation.

ELECTRICAL CONNECTION

The heater should be installed in accordance with the latest edition of the IEE Requirements for Electrical Installation (BS 7671) by a suitably qualified person.

Remove tile adjacent to connection cover plate. Remove side connection cover (2 set screws) Position heater in ceiling (See Fixing)

Position remote switch unit in suitable location. A means of disconnection having a contact separation of 3mm in all poles should be incorporated.

Select cabling with 4 cores and earth of appropriate size for current and volt drop.

Pass cable/s through cord grip in top of unit. Leave sufficient length for connection but ensuring cables do not foul blower unit. Make off connections to connector block and earth stud in accordance with circuit diagram RCH-W-007 (copy on back page and on top of unit)

If remote switching is not required connect power supply to L and N and link L,LI and LII with 1.5sqmm cable. Tighten up cord grip. Replace connection cover plate and ceiling tile.

IMPORTANT : always check to ensure the heating elements cannot be energised without the fan running.

WARNING THIS HEATER MUST BE EARTHED

OVER TEMPERATURE CUT OUT

Should the heater exceed normal operating temperature the over temperature cut out on the heating elements will operate.

To RESET - switch off power to the unit and allow to cool before switching on again. If the problem persists consult a suitably qualified person.



Turnbull & Scott Group
Burnfoot Industrial Estate,
Hawick, Roxburghshire,
Scotland, TD9 8SL
www.Turnbull-scott.co.uk
info@turnbull-scott.co.uk
01450 372053

FIXING

RCHS-3210

This unit is designed for installation in a standard 600mm x 600mm modular ceiling. The front cover can be reduced to a minimum 600mm x 400mm for non standard tiles.

The unit weighs 9kgs. and as such can be mounted directly in a correctly installed modular ceiling. As an added precaution additional ceiling supports can be added adjacent to the heater. If the strength of the ceiling is suspect or for a non standard ceiling system additional fixings can be made to the body of the heater by removing the front cover. Ensure fixings are clear of moving parts and cables.

The mounting clips provided allow mounting flush with the ceiling or can be rotated to allow mounting above the T bar. The latter allows the installation of the egg crate grille.

The minimum height between structural ceiling and top of the T bar is 230mm. If there is limited clearance between the structural and suspended ceilings the unit should be inserted through the mounting hole prior to fitting the clips.

Remove 4 clips and 4 machine screws from packing. Fix clips, with machine screws provided, to screwed inserts in side of unit. Position them as required and tighten up screws. Place unit in ceiling ensuring clips engage securely with top of T bar (see dia 1) or flange (see dia 2)

If access and space is available above the suspended ceiling the grille can be put into position first and the heater positioned over it. If space is limited the heater should be positioned first and then the grille inserted by lifting the heater and sliding the grille in from the side.

RCHR-3210

This unit is designed for installation in a plasterboard or similar ceiling where a free height above the surface of the ceiling is at least 230mm.

A 600mm x 410mm hole should be made in the ceiling and suitably framed.

The unit can be fixed in two ways;

either 1) Remove the front cover of the unit and screw fix through the sides of the unit into the ceiling frame. Replace front cover ensuring all screws are tight and the two shakeproof washers are used.
or 2) Fix clips, with machine screws provided, to screwed inserts in side of unit. Position them as required and tighten up screws. Place unit in ceiling and secure clips to ceiling with woodscrews provided. (see dia 3)

The framed grille is then positioned and fixed by the 6 round headed screws provided.

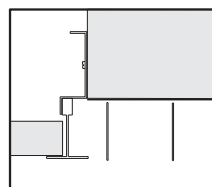

dia.1

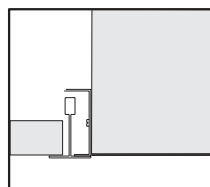

dia.2

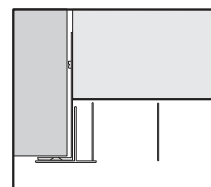

dia.3

MAINTENANCE

Isolate the heater and remove any build up of dust etc. every 6 months. Check that the heater has not been covered or the airflow restricted in any way.

WARRANTY

This product is guaranteed, in accordance with our Conditions of Sale, for a period of 12 months from date of purchase. We will repair or replace, at our discretion, any part found to be defective. We cannot accept responsibility for any consequential liability.

The warranty will be invalid if the heater has not been installed in accordance with these instructions. This does not affect your statutory rights.

The manufacturers reserve the right to change the specification at any time without prior notice EO&E

5

Remote Switch DDH-RSW

IMPORTANT!
Any modification to the switching in this circuit must ensure that the heating elements cannot be energised without the fan running.

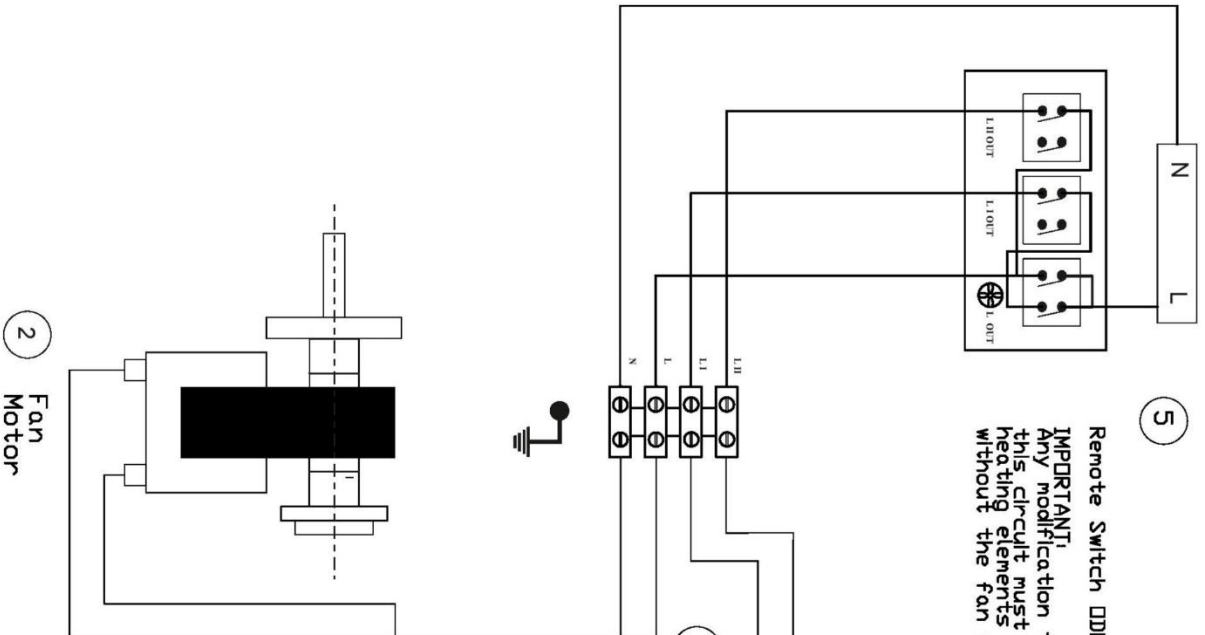

3 Connector Block

1 Heating Element

2 Blower Unit

4 Over temp cut out

Heating element incorporates over temperature cut out in common terminal.

To reset, switch off and allow to cool (5 minutes) then restore supply. Heater does not function again until power has been removed from cut out. Schematic diagram

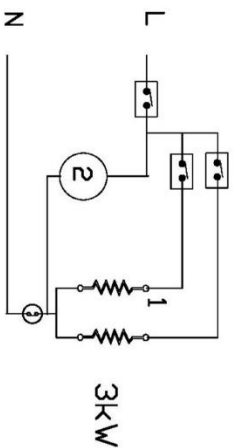

No	Part No	Description
1	B081-01	Heating element
2	C002	Blower/motor
3	F003	Connector block
4		Over temp cut out
5	DDH-RSW	Remote Sw Unit

No	Revision	Date
1	add external cut out	11/04
2	Motor/Fan Change	03/22
3	Remote Switch Wiring Change	11/25

Title: RCHS/R 3210
Recessed Ceiling Htr

Drawn by	NEB	Date	04/11/2025
Scale	1:1	Drawing No.	RCH-W-007
nts		Rev	3

Installation Instructions

The RCHS-3210-TT for Modular T bar Ceilings

The RCHR-3210-TT for Plasterboard Ceilings

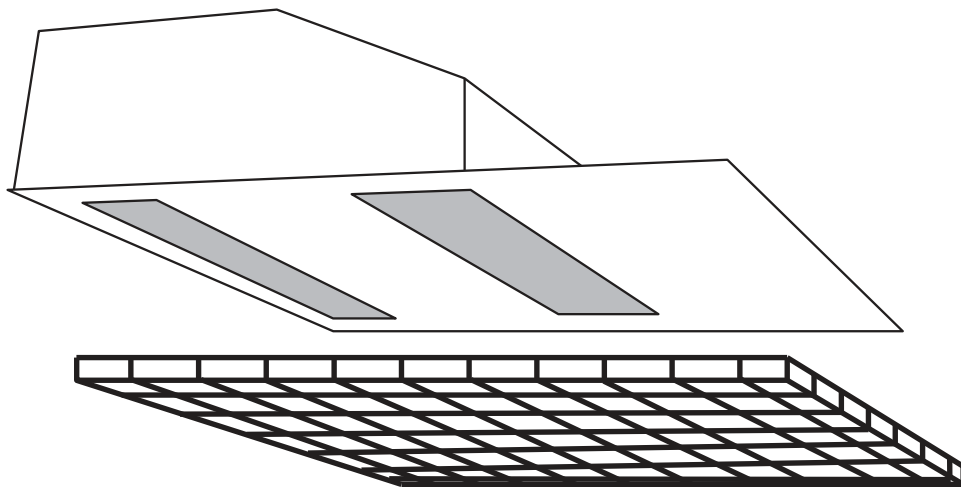

*with **integral relays** to allow connections
of Time clock and Thermostat*

Please retain for future reference

SAFETY

The correct procedures for working at height must be adopted when installing this heater.
The heater must be installed by a suitably qualified person in accordance with current regulations.

CONTENTS

Remove from carton and check contents ;

RCHS-3210-TT

- heater unit
- support clips and 4 no. machine screws
- grille
- 25mm cord grip bush

RCHR-3210-TT

- heater unit
- support clips, 4 no. machine screws and 4 no. woodscrews
- framed grille and 6 no roundhead woodscrews
- 25mm cord grip bush

(Time clock and thermostat not included)

LOCATION

The heater must be installed at a minimum of 2 m and a maximum of 3m from the floor.

The heater can be positioned in the corner tile of a ceiling but for better heat distribution one tile (600mm) from each wall is preferable. The unit should not be positioned over desks, counters or high level display racking wherever a constant flow of heated air may be uncomfortable or cause overheating of equipment.

CONTROL

FAN OUTPUT

The main relay (Terminals T1 and T2) controls the supply to the unit. This has to be switched by a fused 230V supply connection unit incorporating either a time switch / programmer for automatic control (CTTF) or an on/off switch for manual control. The fan runs continuously when the relay is switched on.

HEAT OUTPUT

The second relay controls the switching of the heating elements, they are not switched individually.

TEMPERATURE

The second relay (Terminals T3 and T4) is also switched by a fused 230V supply, usually the temperature controlled circuit. A single thermostat (CRST-16) can control all the heaters. Alternatively several can be used to create zones thus compensating for uneven heat requirements.

The thermostats should be mounted out of the direct influence of the heated airflow.

ELECTRICAL CONNECTION

The heater should be installed in accordance with the latest edition of the IEE Requirements for Electrical Installation (BS 7671) by a suitably qualified person.

Remove tile adjacent to connection cover plate. Remove non captive screw from side connection cover and swivel to side. Position heater in ceiling (See Fixing)

A means of disconnection having a contact separation of 3mm in all poles should be incorporated in the power supply

Select power cabling of appropriate size for current and volt drop for the heater.

Select control cabling with 4 cores and earth of appropriate size for current and volt drop

(Control/motor circuit power consumption approx 50W per unit)

Pass cable/s through cord grip in top of unit. Leave sufficient length for connection but ensuring cables do not foul blower unit. Make off connections to connector block and earth stud in accordance with circuit diagram RCH-W-012 (copy on back page and on top of unit)

Tighten up cord grip. Replace connection cover plate and ceiling tile.

IMPORTANT : always check to ensure the heating elements cannot be energised without the fan running.

WARNING THIS HEATER MUST BE EARTHED

OVER TEMPERATURE CUT OUT

Should the heater exceed normal operating temperature the over temperature cut out on the heating elements will operate. The fan will continue to run.

To RESET - switch off power to the unit and allow to cool before switching on again. If the problem persists consult a suitably qualified person.



Turnbull & Scott Group
Burnfoot Industrial Estate,
Hawick, Roxburghshire,
Scotland, TD9 8SL
www.Turnbull-scott.co.uk
info@turnbull-scott.co.uk
01450 372053

FIXING

RCHS-3210-TT

This unit is designed for installation in a standard 600mm x 600mm modular ceiling. The front cover can be reduced to a minimum 600mm x 400mm for non standard tiles.

The unit weighs 9kgs. and as such can be mounted directly in a correctly installed modular ceiling. As an added precaution additional ceiling supports can be added adjacent to the heater. If the strength of the ceiling is suspect or for a non standard ceiling system additional fixings can be made to the body of the heater by removing the front cover. Ensure fixings are clear of moving parts and cables.

The mounting clips provided allow mounting flush with the ceiling or can be rotated to allow mounting above the T bar. The latter allows the installation of the egg crate grille.

The minimum height between structural ceiling and top of the T bar is 230mm. If there is limited clearance between the structural and suspended ceilings the unit should be inserted through the mounting hole prior to fitting the clips.

Remove 4 clips and 4 machine screws from packing. Fix clips, with machine screws provided, to screwed inserts in side of unit. Position them as required and tighten up screws. Place unit in ceiling ensuring clips engage securely with top of T bar (see dia 1) or flange (see dia 2)

If access and space is available above the suspended ceiling the grille can be put into position first and the heater positioned over it. If space is limited the heater should be positioned first and then the grille inserted by lifting the heater and sliding the grille in from the side.

RCHR-3210-TT

This unit is designed for installation in a plasterboard or similar ceiling where a free height above the surface of the ceiling is at least 230mm.

A 600mm x 410mm hole should be made in the ceiling and suitably framed.

The unit can be fixed in two ways;

either 1) Remove the front cover of the unit and screw fix through the sides of the unit into the ceiling frame. Replace front cover ensuring all screws are tight and the two shakeproof washers are used.
or 2) Fix clips, with machine screws provided to screwed inserts in side of unit. Position them as required and tighten up screws. Place unit in ceiling and secure clips to ceiling with woodscrews provided. (see dia 3)

The framed grille is then positioned and fixed by the 6 round headed screws provided.

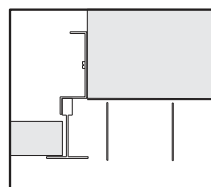

dia.1

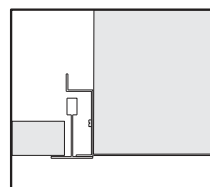

dia.2

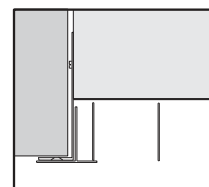

dia.3

MAINTENANCE

Isolate the heater and remove any build up of dust etc. every 6 months. Check that the heater has not been covered or the airflow restricted in any way.

WARRANTY

This product is guaranteed, in accordance with our Conditions of Sale, for a period of 12 months from date of purchase. We will repair or replace, at our discretion, any part found to be defective. We cannot accept responsibility for any consequential liability.

The warranty will be invalid if the heater has not been installed in accordance with these instructions. This does not affect your statutory rights.

The manufacturers reserve the right to change the specification at any time without prior notice EO&E

Warning
Multiple supply isolate ALL before opening connection cover.

Relay coil 1(T1T2) to be energised by 230V from timer on/off controlled and fused supply
Relay coil 2(T3T4) to be energised by 230V from thermostat controlled and fused supply

Heating element incorporates over temperature cut out .
Fan continues to run if cut out operates.

To reset:
Switch off and allow to cool (5 minutes) then restore supply

Heater does not function again until power has been removed from cut out.

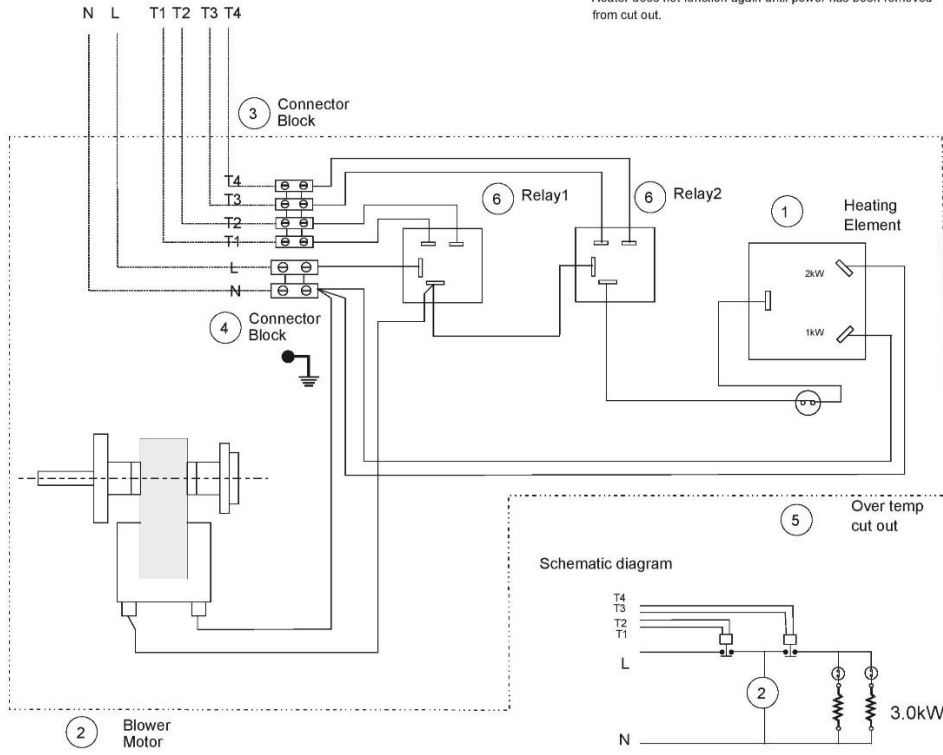

No	Part No	Description
1	B081-01	Heating element
2	C002	Blower/motor
3	F003	16A Con block
4	F036-1	40A Con block
5		Over temp cut outs
6	E128	Relay

No	Revision	Date
1	Change relays	01/11
2	Motor/Fan Change	03/22
3	Relay link wiring change	02/25
4	Connector Block Changed	10/25

Title RCHS/R/B-3210-TT
Recessed Ceiling Htr
with integral relays

Drawn by JS Date 07/10/25

Scale Drawing No. RCH-W-012 Rev 4

L011

One relay is connected in the incoming live to control the on and off of the heater. A second relay is connected between the first relay and the elements to control the heating elements only.

The fan motor will run continuously when there is power to the heater through relay 1

Each relay is independently switched via a fused power supply controlled by time clock or thermostat

See RCH-W-012 and RCH-W-013 for heater circuit detail

Note: Multiple supply isolate ALL before opening connection cover.

Thermostat

Note
It is necessary to link Terminals 2 and 3 in the CTF unit.

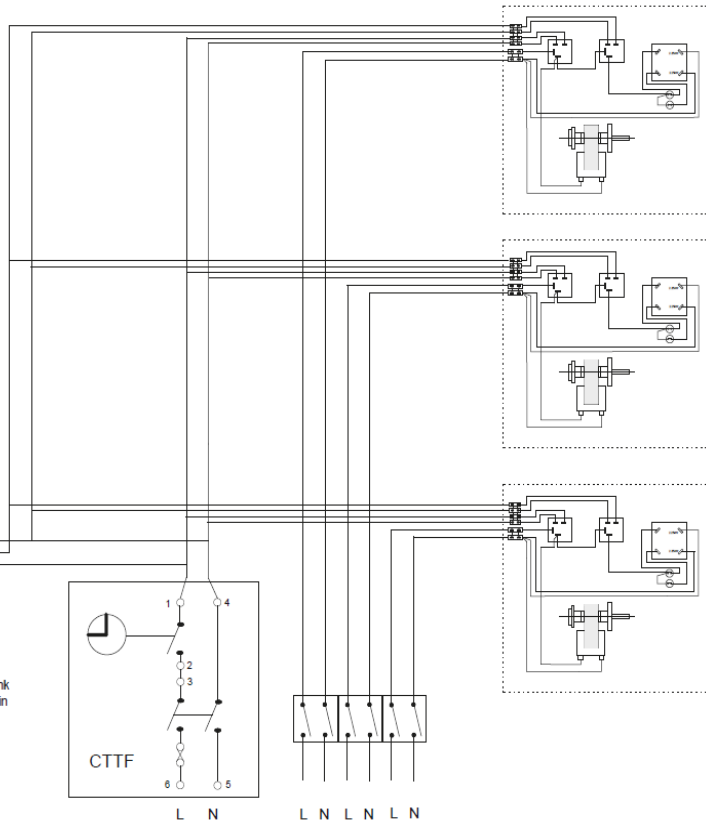

No	Part No	Description
1		
2		
3		
4		
5		
6		
7		

No	Revision	Date
1		
2		

Title Typical site connection
RCHX-xxxx TT with CTF
Recessed Ceiling Htr

Drawn by NEB Date 30.08.07

Scale Drawing No. RCH-W-014A Rev 0

L011

Installation Instructions

The RCHS 4200 for Modular T bar Ceilings

The RCHR 4200 for Plasterboard Ceilings

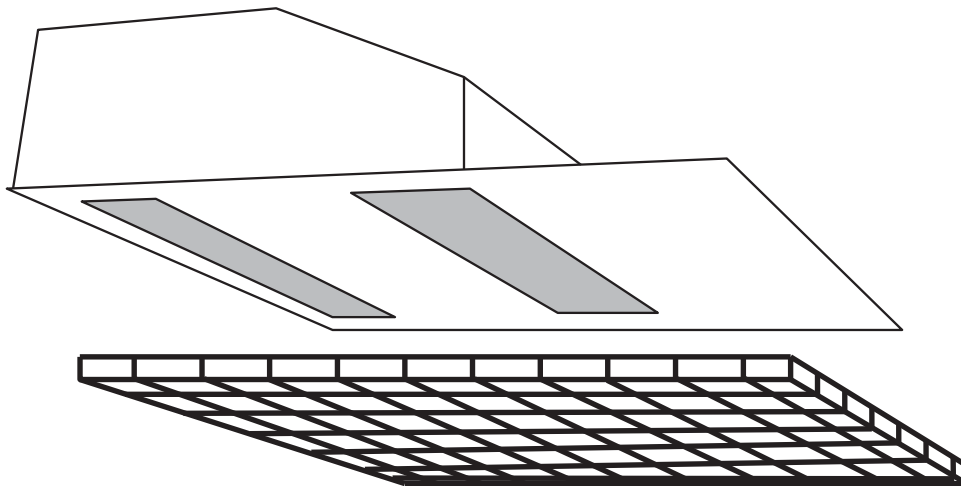

Complete with **REMOTE SWITCH UNIT**
for Fan only, 4.5 and 2.25kW

Please retain for future reference

SAFETY

The correct procedures for working at height must be adopted when installing this heater.

The heater must be installed by a suitably qualified person in accordance with current regulations.

CONTENTS

Remove from carton and check contents ;

RCHS-4200

- heater unit
- support clips and 4 no. machine screws
- grille
- ODH-RSW three switch control unit
- 25mm cord grip bush

RCHR-4200

- heater unit
- support clips, 4 no. machine screws and 4 no. woodscrews
- framed grille and 6 no roundhead woodscrews
- ODH-RSW three switch control unit
- 25mm cord grip bush

LOCATION

The heater must be installed at a minimum of 2m and a maximum of 3m from the floor.

The heater can be positioned in the corner tile of a ceiling but for better heat distribution one tile (600mm) from each wall is preferable.

The unit should not be positioned over desks, counters or high level display racking wherever a constant flow of heated air may be uncomfortable or cause overheating of equipment.

CONTROL

Remote Switch

The Remote Switching Unit allows ON/OFF, Fan only with 2.25 or 4.5 kW.

Thermostat

A thermostat of 25A rating can be connected in the power supply to the Remote switch thus switching the unit off totally when set temperature is reached. Alternatively a thermostat and contactor can be used.

ELECTRICAL CONNECTION

The heater should be installed in accordance with the latest edition of the IEE Requirements for Electrical Installation (BS 7671) by a suitably qualified person.

Remove tile adjacent to connection cover plate. Remove side connection cover (2 set screws) Position heater in ceiling (See Fixing)

Position remote switch unit in suitable location. A suitable means of disconnection having a contact separation of 3mm in all poles should be incorporated.

Select cabling with 4 cores and earth of appropriate size for current and volt drop .

Pass cable/s through cord grip in top of unit. Leave sufficient length for connection but ensuring cables do not foul blower unit. Make off connections to connector block and earth stud in accordance with circuit diagram RCH-W-008 (copy on back page and on top of unit)

If remote switching is not required connect power supply to L and N and link L,LI and LII with 1.5sqmm cable. Tighten up cord grip. Replace connection cover plate and ceiling tile.

IMPORTANT : always check to ensure the heating elements cannot be energised without the fan running.

WARNING THIS HEATER MUST BE EARTHED

OVER TEMPERATURE CUT OUT

Should the heater exceed normal operating temperature the over temperature cut out on the heating elements will operate.

To RESET - switch off power to the unit and allow to cool before switching on again. If the problem persists consult a suitably qualified person.



Turnbull & Scott Group
Burnfoot Industrial Estate,
Hawick, Roxburghshire,
Scotland, TD9 8SL
www.Turnbull-scott.co.uk
info@turnbull-scott.co.uk
01450 372053

FIXING

RCHS-4200

This unit is designed for installation in a standard 600mm x 600mm modular ceiling. The front cover can be reduced to a minimum 600mm x 400mm for non standard tiles.

The unit weighs 9kgs. and as such can be mounted directly in a correctly installed modular ceiling. As an added precaution additional ceiling supports can be added adjacent to the heater. If the strength of the ceiling is suspect or for a non standard ceiling system additional fixings can be made to the body of the heater by removing the front cover. Ensure fixings are clear of moving parts and cables.

The mounting clips provided allow mounting flush with the ceiling or can be rotated to allow mounting above the T bar. The latter allows the installation of the egg crate grille.

The minimum height between structural ceiling and top of the T bar is 230mm. If there is limited clearance between the structural and suspended ceilings the unit should be inserted through the mounting hole prior to fitting the clips.

Remove 4 clips and 4 machine screws from packing. Fix clips, with machine screws provided, to screwed inserts in side of unit. Position them as required and tighten up screws. Place unit in ceiling ensuring clips engage securely with top of T bar (see dia 1) or flange (see dia 2)

If access and space is available above the suspended ceiling the grille can be put into position first and the heater positioned over it. If space is limited the heater should be positioned first and then the grille inserted by lifting the heater and sliding the grille in from the side.

RCHR-4200

This unit is designed for installation in a plasterboard or similar ceiling where a free height above the surface of the ceiling is at least 230mm.

A 600mm x 410mm hole should be made in the ceiling and suitably framed.

The unit can be fixed in two ways;

either 1) Remove the front cover of the unit and screw fix through the sides of the unit into the ceiling frame. Replace front cover ensuring all screws are tight.
or 2) Fix clips, with machine screws provided, to screwed inserts in side of unit. Position them as required and tighten up screws. Place unit in ceiling and secure clips to ceiling with woodscrews provided. (see dia 3)

The framed grille is then positioned and fixed by the 6 round headed screws provided.

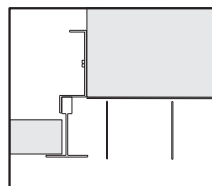

dia.1

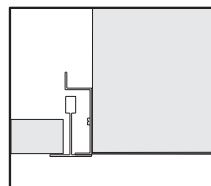

dia.2

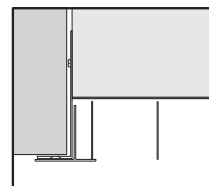

dia.3

MAINTENANCE

Isolate the heater and remove any build up of dust etc. every 6 months. Check that the heater airflow has not been restricted in any way.

WARRANTY

This product is guaranteed, in accordance with our Conditions of Sale, for a period of 12 months from date of purchase. We will repair or replace, at our discretion, any part found to be defective. We cannot accept responsibility for any consequential liability.

The warranty will be invalid if the heater has not been installed in accordance with these instructions. This does not affect your statutory rights.

The manufacturers reserve the right to change the specification at any time without prior notice EO&E



Turnbull & Scott Group
Burnfoot Industrial Estate,
Hawick, Roxburghshire,
Scotland, TD9 8SL
www.Turnbull-scott.co.uk
info@turnbull-scott.co.uk
01450 372053

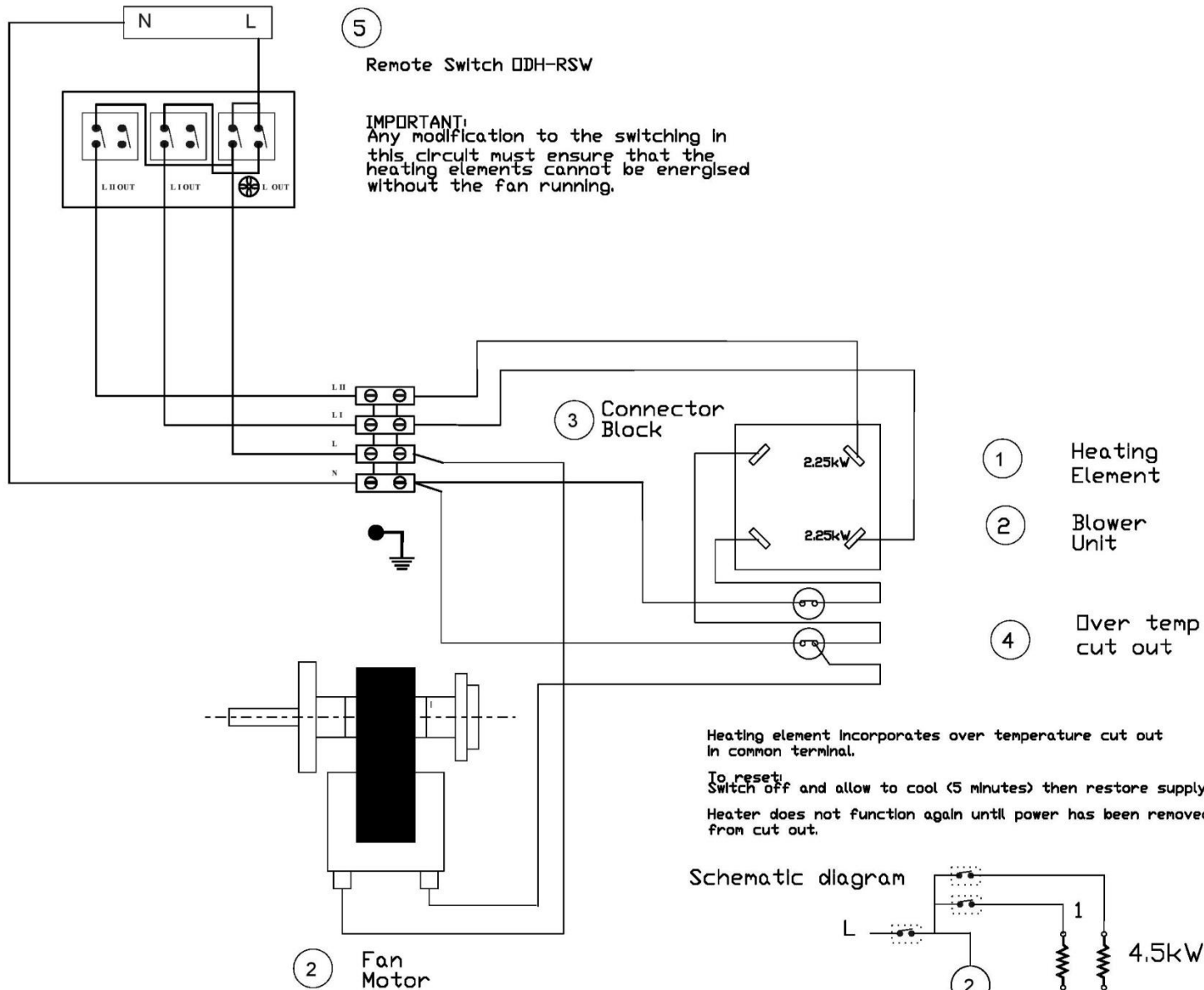

Schematic diagram

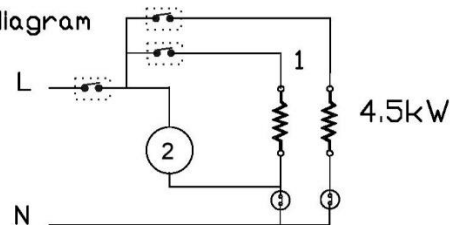

No	Part No	Description
1	B082-01	Heating element
2	C002	Blower/Motor
3	F036-1	Connector block
4		Over temp cut outs
5	DDH-RSW	Remote Switch Unit

No	Revision	Date
1	Add external cut outs	11/04
2	Change remote switch	01/07
3	Blower/Motor Change	03/22
4	Connector Block Changed	10/25
5	Remote Switch wiring Changed	11/25

Title RCHS/R 4200
Recessed Ceiling Htr.

Drawn by NEB Date 04/11/2025

Scale Drawing No. RCH-W-008 Rev 5

Installation Instructions

The RCHS 4200-TT for Modular T bar Ceilings

The RCHR 4200-TT for Plasterboard Ceilings

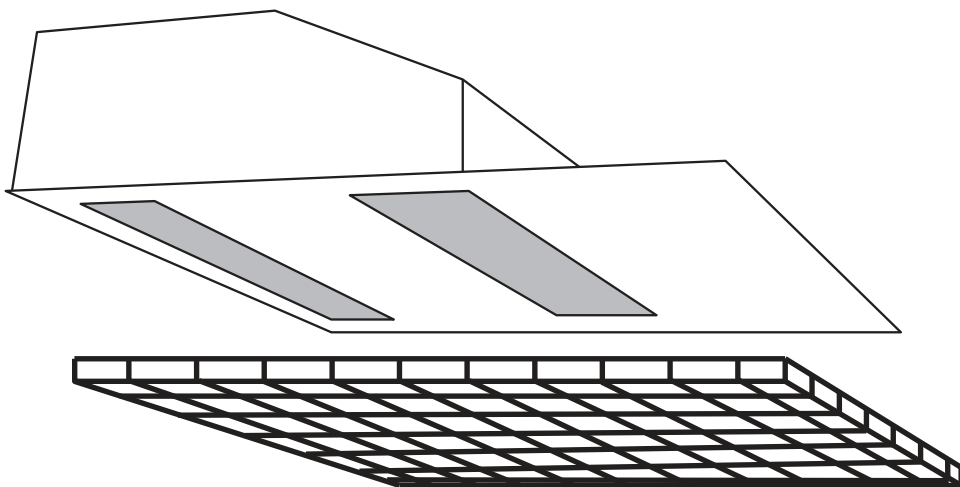

*with **integral relays** to allow connections
of Time clock and Thermostat*

Please retain for future reference

SAFETY

The correct procedures for working at height must be adopted when installing this heater.
The heater must be installed by a suitably qualified person in accordance with current regulations.

CONTENTS

Remove from carton and check contents ;

RCHS-4200-TT

- heater unit
- support clips and 4 no. machine screws
- grille
- 25mm cord grip bush

RCHR-4200-TT

- heater unit
- support clips, 4 no. machine screws and 4 no. woodscrews
- framed grille and 6 no roundhead woodscrews
- 25mm cord grip bush

(Time clock and thermostat not included)

LOCATION

The heater must be installed at a minimum of 2m and a maximum of 3m from the floor.

The heater can be positioned in the corner tile of a ceiling but for better heat distribution one tile (600mm) from each wall is preferable. The unit should not be positioned over desks, counters or high level display racking wherever a constant flow of heated air may be uncomfortable or cause overheating of equipment.

CONTROL

FAN OUTPUT

The main relay (Terminals T1 and T2) controls the supply to the unit. This has to be switched by a fused 230V supply connection unit incorporating either a time switch / programmer for automatic control (CTTF) or an on/off switch for manual control. The fan runs continuously when the relay is switched on.

HEAT OUTPUT

The second relay controls the switching of the heating elements, they are not switched individually.

TEMPERATURE

The second relay (Terminals T3 and T4) is also switched by a fused 230V supply, usually the temperature controlled circuit. A single thermostat (CRST-16) can control all the heaters. Alternatively several can be used to create zones thus compensating for uneven heat requirements.

The thermostats should be mounted out of the direct influence of the heated airflow.

ELECTRICAL CONNECTION

The heater should be installed in accordance with the latest edition of the IEE Requirements for Electrical Installation (BS 7671) by a suitably qualified person.

Remove tile adjacent to connection cover plate. Remove non captive screw from side connection cover and swivel to side. Position heater in ceiling (See Fixing)

A means of disconnection having a contact separation of 3mm in all poles should be incorporated in the power supply.

Select power cabling of appropriate size for current and volt drop for the heater.

Select control cabling with 4 cores and earth of appropriate size for current and volt drop

(Control/motor circuit power consumption approx 50W per unit)

Pass cable/s through cord grip in top of unit. Leave sufficient length for connection but ensuring cables do not foul blower unit. Make off connections to connector block and earth stud in accordance with circuit diagram RCH-W-013 (copy on back page and on top of unit)

Tighten up cord grip. Replace connection cover plate and ceiling tile.

IMPORTANT : always check to ensure the heating elements cannot be energised without the fan running.

WARNING THIS HEATER MUST BE EARTHED

OVER TEMPERATURE CUT OUT

Should the heater exceed normal operating temperature the over temperature cut out on the heating elements will operate. The fan will continue to run.

To RESET - switch off power to the unit and allow to cool before switching on again. If the problem persists consult a suitably qualified person.



Turnbull & Scott Group
Burnfoot Industrial Estate,
Hawick, Roxburghshire,
Scotland, TD9 8SL
www.Turnbull-scott.co.uk
info@turnbull-scott.co.uk
01450 372053

FIXING

RCHS-4200-TT

This unit is designed for installation in a standard 600mm x 600mm modular ceiling. The front cover can be reduced to a minimum 600mm x 400mm for non standard tiles.

The unit weighs 9kgs. and as such can be mounted directly in a correctly installed modular ceiling. As an added precaution additional ceiling supports can be added adjacent to the heater. If the strength of the ceiling is suspect or for a non standard ceiling system additional fixings can be made to the body of the heater by removing the front cover. Ensure fixings are clear of moving parts and cables.

The mounting clips provided allow mounting flush with the ceiling or can be rotated to allow mounting above the T bar. The latter allows the installation of the egg crate grille.

The minimum height between structural ceiling and top of the T bar is 230mm. If there is limited clearance between the structural and suspended ceilings the unit should be inserted through the mounting hole prior to fitting the clips.

Remove 4 clips and 4 machine screws from packing. Fix clips, with machine screws provided, to screwed inserts in side of unit. Position them as required and tighten up screws. Place unit in ceiling ensuring clips engage securely with top of T bar (see dia 1) or flange (see dia 2)

If access and space is available above the suspended ceiling the grille can be put into position first and the heater positioned over it. If space is limited the heater should be positioned first and then the grille inserted by lifting the heater and sliding the grille in from the side.

RCHR-4200-TT

This unit is designed for installation in a plasterboard or similar ceiling where a free height above the surface of the ceiling is at least 230mm.

A 600mm x 410mm hole should be made in the ceiling and suitably framed.

The unit can be fixed in two ways;

either 1) Remove the front cover of the unit and screw fix through the sides of the unit into the ceiling frame. Replace front cover ensuring all screws are tight.

or 2) Fix clips, with machine screws provided, to screwed inserts in side of unit. Position them as required and tighten up screws. Place unit in ceiling and secure clips to ceiling with woodscrews provided. (see dia 3)

The framed grille is then positioned and fixed by the 6 round headed screws provided.

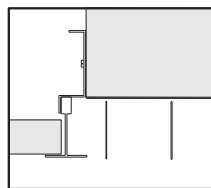

dia.1

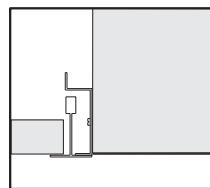

dia.2

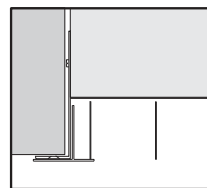

dia.3

MAINTENANCE

Isolate the heater and remove any build up of dust etc. every 6 months. Check that the heater airflow has not been restricted in any way.

WARRANTY

This product is guaranteed, in accordance with our Conditions of Sale, for a period of 12 months from date of purchase. We will repair or replace, at our discretion, any part found to be defective. We cannot accept responsibility for any consequential liability.

The warranty will be invalid if the heater has not been installed in accordance with these instructions. This does not affect your statutory rights.

The manufacturers reserve the right to change the specification at any time without prior notice EO&E

Warning
Multiple supply isolate ALL before opening connection cover.

Relay coil 1(T1,T2) to be energised by 230V from timer on/off controlled and fused supply
Relay coil 2 (T3,T4) to be energised by 230V from thermostat controlled and fused supply

Heating element incorporates over temperature cut out .
Fan continues to run if cut out operates.

To reset:
Switch off and allow to cool (5 minutes) then restore supply

Heater does not function again until power has been removed from cut out.

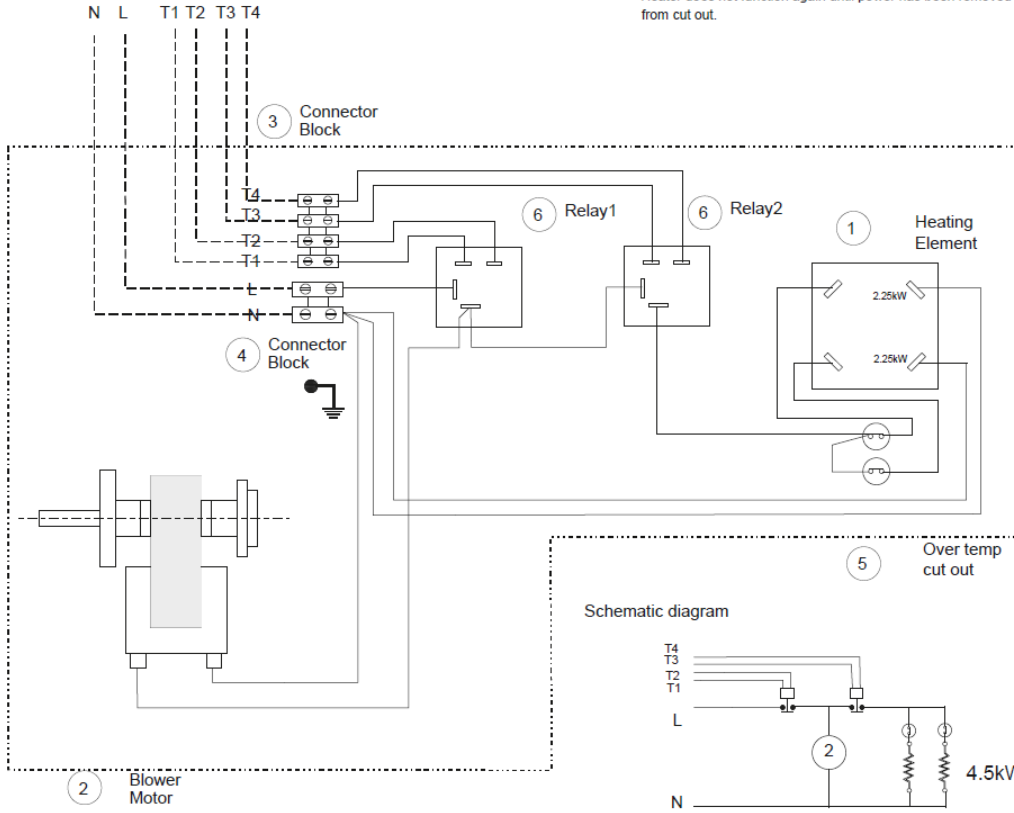

No	Part No	Description
1.	B082-01	Heating element
2.	C002	Blower/Motor
3.	F003	16A Con block
4.	F040	40A Con block
5.		Over temp cut outs..
6.	E128	Relay

No	Revision	Date
1	Change relays	04/08
2	Motor Blower change	03/22

Title RCHS/R/B-4200-TT
Recessed Ceiling Htr
with integral relays

Drawn by NEB Date 10/03/2022

Scale Drawing No. RCH-W-013 Rev 2

L011

One relay is connected in the incoming live to control the on and off of the heater. A second relay is connected between the first relay and the elements to control the heating elements only.

The fan motor will run continuously when there is power to the heater through relay 1

Each relay is independently switched via a fused power supply controlled by time clock or thermostat

See RCH-W-012 and RCH-W-013 for heater circuit detail

Note: Multiple supply isolate ALL before opening connection cover.

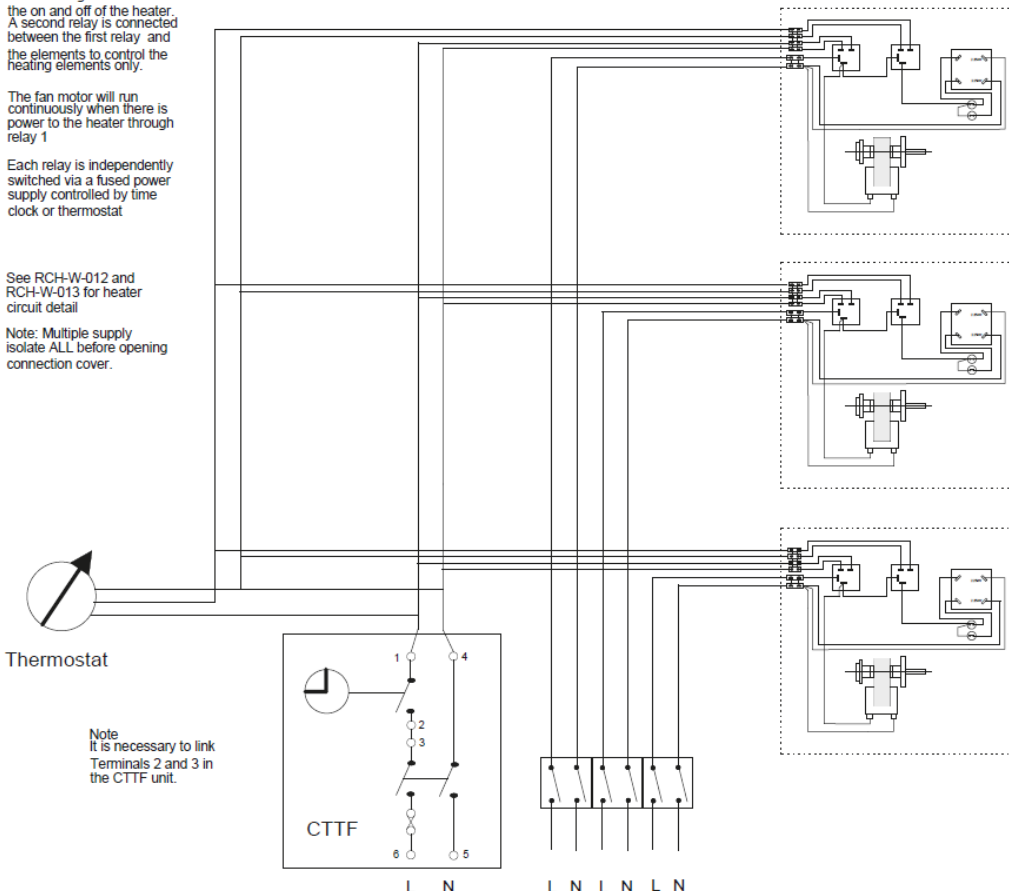

Note
It is necessary to link
Terminals 2 and 3 in
the CTF unit.

No	Part No	Description
1		
2		
3		
4		
5		
6		
7		

No	Revision	Date
1		
2		

Title Typical site connection
RCHX-xxxx TT with CTF
Recessed Ceiling Htr

Drawn by NEB Date 30.08.07

Scale Drawing No. RCH-W-014A Rev 0

L011

Installation Instructions

The RCHB 3210 Ceiling heater for surface mounting

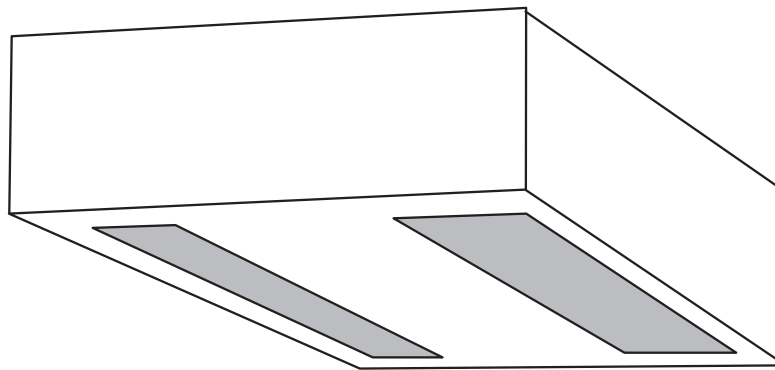

Complete with **REMOTE SWITCH UNIT**
for Fan only, 3, 2 and 1kW

Please retain for future reference

SAFETY

The correct procedures for working at height must be adopted when installing this heater.

The heater must be installed by a suitably qualified person in accordance with current regulations.

CONTENTS

Remove from carton and check contents ;

- heater unit
- RCH-RSW three switch control unit

LOCATION

The heater must be installed at a minimum of 2 m and a maximum of 3m from the floor.

The heater can be positioned in the corner of a ceiling but for better heat distribution at least 600mm from each wall is preferable.

The unit should not be positioned over desks, counters or high level display racking wherever a constant flow of heated air may be uncomfortable or cause overheating of equipment.

CONTROL

Remote Switch

The Remote Switching Unit allows ON/OFF, Fan only with 1,2 or 3 kW.

Thermostat (CRST16)

A thermostat of 16A rating can be connected in the power supply to the Remote switch thus switching the unit off totally when set temperature is reached. Alternatively a thermostat and contactor can be used.

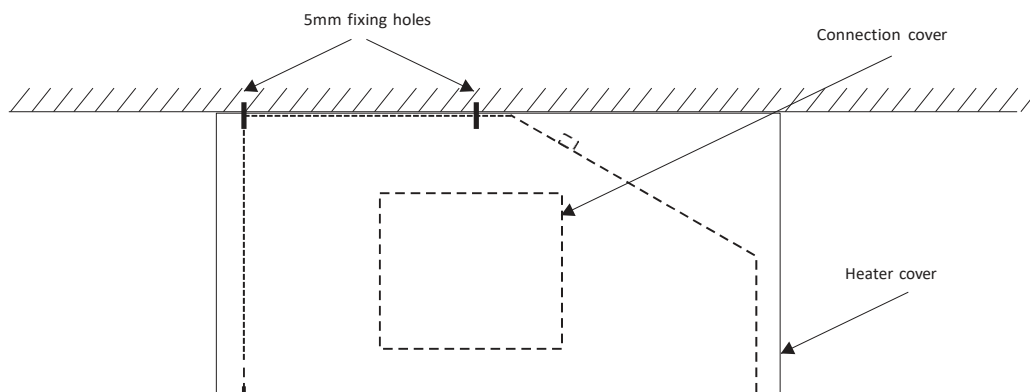

FIXING

This heater is designed for surface installation to any ceiling that can adequately support the unit. The unit weighs 9kgs.

Remove the front cover of the unit

Fixings are made through the top flat section of the heater body using the 4 No 5mm holes provided. This section must be flat on the ceiling as the edges of the cover are designed to fit against the ceiling.

Securely fix the heater and make off the electrical connections taking into account the routing of cables in relation to the cover. Ensure fixings and cables are clear of moving parts and the heater elements.

Re fix the cover ensuring the fan outlet is adjacent to the smaller outlet grille.

ELECTRICAL CONNECTION

The heater should be installed in accordance with the latest edition of the IEE Requirements for Electrical Installation (BS 7671) by a suitably qualified person.

Position heater on ceiling (See Fixing)

Remove side connection cover (2 set screws)

Position remote switch unit in suitable location.

A means of disconnection having a contact separation of 3mm in all poles should be incorporated.

Select cabling with 4 cores and earth of appropriate size for current and volt drop.

Pass cable/s through cord grip in top of unit. Leave sufficient length for connection but ensuring cables do not foul blower unit. Make off connections to connector block and earth stud in accordance with circuit diagram RCH-W-007 (copy on back page and on top of unit)

If remote switching is not required connect power supply to L and N and link L,LI and LII with 1.5sqmm cable.

Tighten up cord grip. Replace connection cover plate. Replace heater cover.

IMPORTANT : always check to ensure the heating elements cannot be energised without the fan running.

WARNING THE HEATER MUST BE EARTHED

OVER TEMPERATURE CUT OUT

Should the heater exceed normal operating temperature the over temperature cut out on the heating elements will operate.

To RESET - switch off power to the unit and allow to cool before switching on again. If the problem persists consult a suitably qualified person.

MAINTENANCE

Isolate the heater and remove any build up of dust etc. every 6 months. Check that the heater has not been covered or the airflow restricted in any way.

WARRANTY

This product is guaranteed, in accordance with our Conditions of Sale, for a period of 12 months from date of purchase. We will repair or replace, at our discretion, any part found to be defective. We cannot accept responsibility for any consequential liability.

The warranty will be invalid if the heater has not been installed in accordance with these instructions.

This does not affect your statutory rights.

The manufacturers reserve the right to change the specification at any time without prior notice EO&E

Remote Switch DDH-RSW

IMPORTANT!
Any modification to the switching in this circuit must ensure that the heating elements cannot be energised without the fan running.

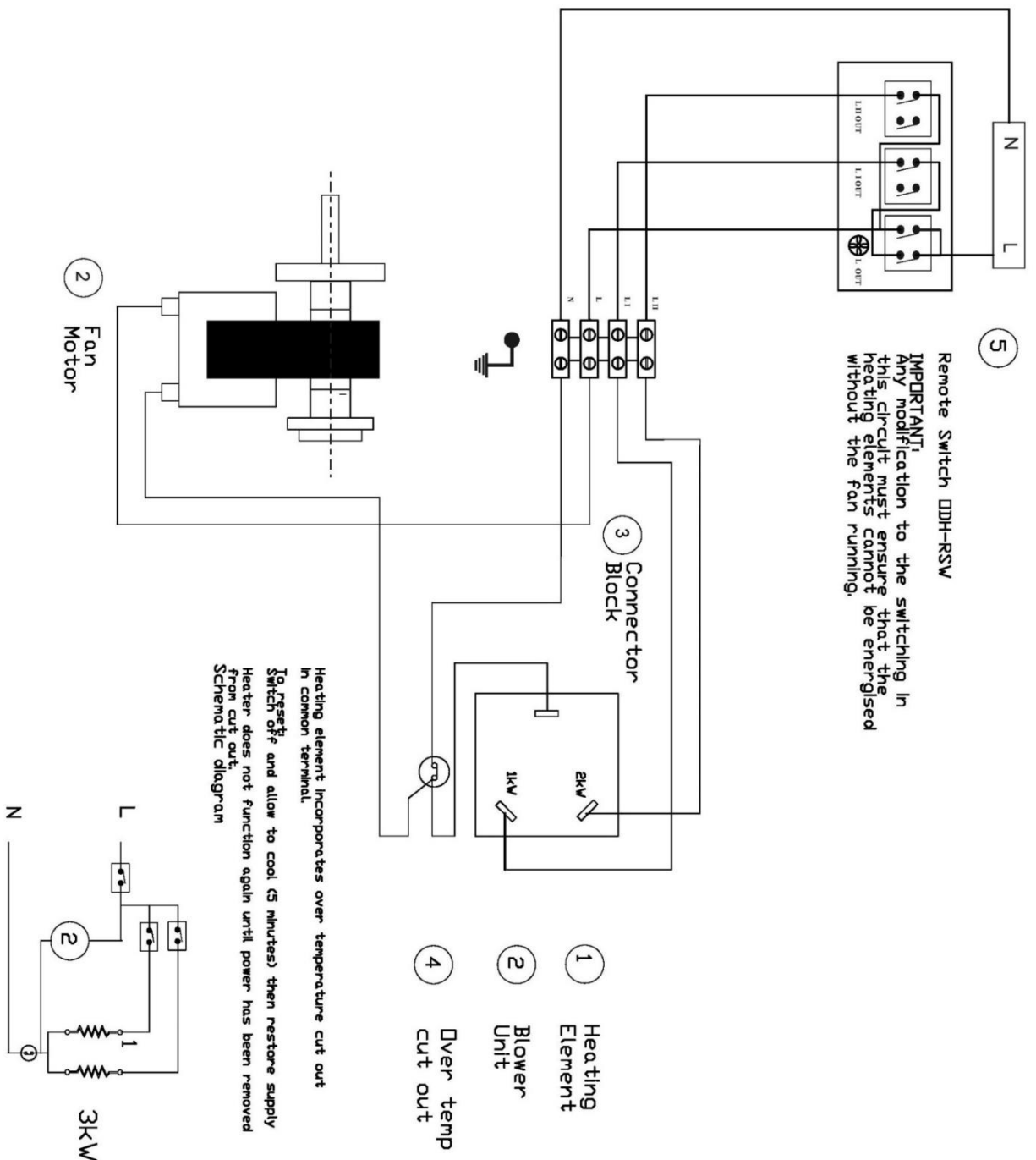

Heating element incorporates over temperature cut out in common terminal.
To reset, switch off and allow to cool (5 minutes) then restore supply. Heater does not function again until power has been removed from cut out.
Schematic diagram

- 1 Heating Element
- 2 Blower Unit
- 4 Over temp cut out

No	Part No	Description	Date
1	B081-01	Heating element	11/04
2	C002	Blower/motor	03/22
3	F003	Connector block	11/25
4	DDH-RSW	Over temp cut out	
5	DDH-RSW	Remote Sw Unit	

No	Revision	Date
1	add external cut out	11/04
2	Motor/Fan Change	03/22
3	Remote Switch Wiring Change	11/25

Title RCHS/R 3210	
Recessed Ceiling Htr	
Drawn by NEB	Date 04/11/2025
Scale Drawing No. RCH-W-007	Rev 3