

HGI Portable Electric Fan Heater



COMMERCIAL &
INDUSTRIAL
HEAT

Part of
Turnbull & Scott™

HGI | Portable Electric Fan Heater



PRODUCT DESCRIPTION

The robust freestanding HGI Fan Heater is ideal for heating large spaces and can be used in factories, warehouses, workshops, marine vessels, stables, barns, sheds, garages or in any other large commercial or industrial space. Lightweight and portable, it is also ideal for use on construction sites as well as being used for climate control, drying paint and plaster, anti-condensation and frost protection.

The range comes in 10 model options with heat outputs from 2kW to 24kW depending on the model selected.

The IP54 rating of the heater provides tough protection against splashing water and dust and the galvanised housing protects against corrosion. The weatherproof housing and stainless steel heating elements ensures longevity and that the heater can be used outdoors.

The metal tubular frame provides stability when placed directly on the floor and when transported. The HGI fan heater can also be fitted with additional wall brackets should wall mounting be required (purchased separately).

Built-in controls include a thermostat and five-position switch to control the heat output and fan speed. It is also compatible with any of our range of additional time controls and thermostats.



HGI | Portable Electric Fan Heater

FEATURES

- 2kW to 24kW heat output model options
- Single phase or three phase electrical supply options
- Suitable for tough environments with IP54 rating
- Integrated capillary type thermostat
- Built-in five position switch to control heat output and speed
- Over-temperature cutout at fixed setpoint of 165°C
- Anti-corrosion stainless steel heating elements
- Galvanised housing power coated in RAL5003
- Robust tubular frame for floor positioning
- Optional wall bracket available for wall-mounting

CONTROL

All models are supplied with an internal five position control switch to control heat output and fan speed:

- Off
- Fan only
- ½ fan + ½ heat
- Fan + ½ heat
- Fan + heat

Note: Should customers opt to use these heaters in fixed location and hardwire them to the electricity supply, an electrical contactor will be required on 400V 3-phase models for installation of wall mounted thermostatic controls.

TECHNICAL SPECIFICATON

Product Code	kW	Volts	Power Consumption	Width mm	Height mm	Depth mm	Weight kg
FHM 2	2	230	8.7A	385	454	350	15
FHM 3	3	230	13.05A	385	454	350	15
FHC 2	2	110	18.18A	385	454	350	15
FHC 3	3	110	27.27A	385	454	350	15
FH 3	3	400	4.4A per phase	385	454	350	15
FH 6	6	400	8.7A per phase	385	454	350	16
FH 9	9	400	13.05A per phase	385	454	350	16
FH 12	12	400	17.4A per phase	430	513	462	16
FH 15	15	400	21.8A per phase	430	513	462	23
FH 18	18	400	26.1A per phase	430	513	462	23
FH 21	21	400	30.5A per phase	430	513	462	27
FH 24	24	400	34.8A per phase	430	513	462	27

HGI | Portable Electric Fan Heater

INSTALLATION & MAINTENANCE

The fan heaters have an integral capillary type thermostat which will measure the ambient air temperature and control the heating elements. This is a hand-operated rotary knob with scale. This thermostat has an automatic reset.

The fan heaters also have a limit switch, an over-temperature cutout. This over-temperature cutout has a fixed setpoint at 165°C and measures the outgoing air temperature. If the temperature exceeds this, the heating elements will be switched off. The over-temperature cutout must be manually reset by pressing the red button next to the thermostat. Potential problems could be a defect fan or overly dirty elements.

The fan heater can be placed on the floor in the robust frame provided or can be hung on the wall with the optional wall mounting bracket. This must be mounted securely and free of obstacles that will obstruct airflow to the inlet and outlet.

All electrical connections should be made by a suitably qualified person in accordance with the latest edition of the IEE Requirements for Electrical Installation (BS 7671:2008).

Periodic inspection of the fan heater must be carried out for the presence of dirt and dust. Internal components such as fan motor or heating elements must be cleaned with compressed air to avoid overheating

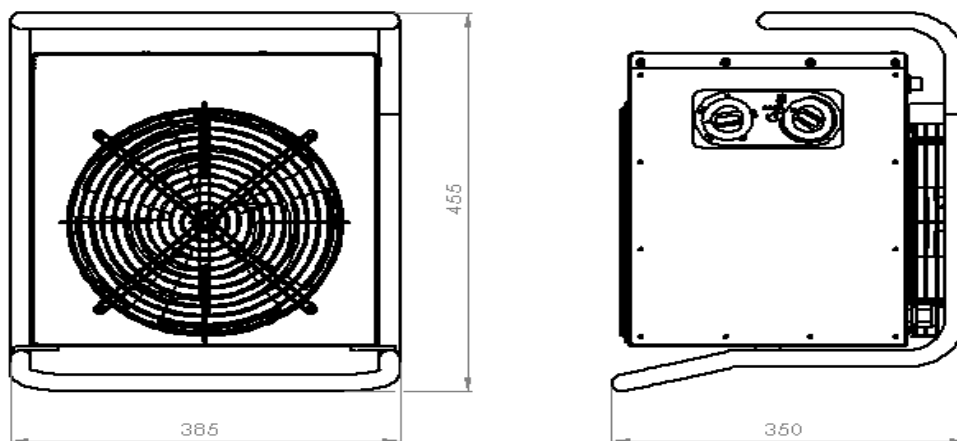

Models FHM 2 - FH 9

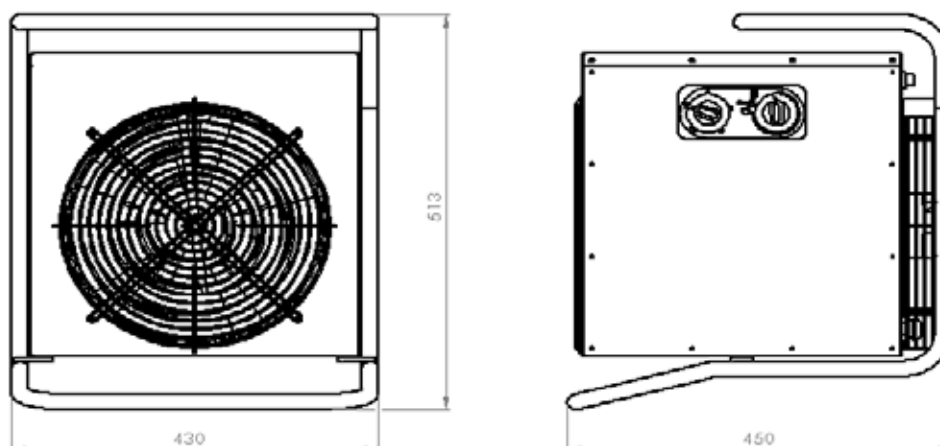

Models FH 12 - FH 24

COMMERCIAL &
INDUSTRIAL
HEAT

Part of
Turnbull & Scott™

Unit 1a, Burnfoot Industrial Estate
Roxburghshire,
Scotland, TD9 8SL

www.turnbull-scott.co.uk

01450 372 103