

# Installation Instructions

## CUH Heavy Duty Unit Heater

---

**ATTENTION: Read carefully before attempting to install, operate or service the CUH Heavy Duty Unit Heater.**

### PRODUCT FEATURES

Standard heating capacities

3.3 KW 230V and 400V 3N

5kW 230V and 400V 3N

7.5kW 230V and 400V 3N

10kW 400V 3N

15kW 400V 3N

20kW 400V 3N

25kW 400V 3N

30kW 400V 3N

40kW 400V 3N

Optional wall/ceiling or vertical mounting brackets (as required).

Four position weld nuts supplied in case top and back for field mounting by threaded rods or eye bolt with chain. (Hardware supplied by others).

Note:- Threads are 5/16" UNC

Specially designed inlet louvre allows the fan to pull cool air evenly across the high mass all-steel element.

Outward drawn venturi and adjustable louvre assembly further directs the outlet air in a uniform pattern to meet specific air pattern requirements in either the horizontal or vertical mounting position.

Optional radial or anemostat diffusers lending air pattern versatility when mounted vertically

Various control kits, thermostats, summer fan switch, heat recovery thermostat.

24 volt low voltage control circuit optional on contactor and transformer models

Single point terminal board wiring of integral control kits.

Roomy control box with access door locked into position by two (2) 1/4 turn fasteners and screws for ease of installation.

---

**IMPORTANT RETAIN THESE INSTRUCTIONS FOR FUTURE REFERENCE**

## PROPER LOCATION INSTRUCTIONS

Once the total heating load is calculated, the quantity and capacity of the unit heaters must be determined. A large number of low-capacity heaters provides more uniform heat distribution. This is recommended when the area will be occupied by a relatively large number of sedentary personnel, (i.e. working on production lines and at benches.)

A large number of smaller capacity unit heaters tends to prevent hot drafts, reduces noise levels, and increases diversity of load to help reduce electrical demand and operating costs.

In warehouses where even heat distribution and constant temperatures are less important, a smaller number of high capacity units can be used -- in many cases reducing installation cost. To maintain reasonable heat distribution and reduce severe stratification, even in lower bay areas, the total air volume of the space should pass through the unit heaters about three times per hour.

It is important that the rated voltage of the heating equipment matches the supply voltage. Supply voltage in excess of the heater rated voltage can damage equipment. Supply voltage lower than the rated heater voltage will decrease heater output as well as run the risk of damaging some components.

Horizontal unit heaters are recommended in low bay areas with maximum 5 metre ceilings. These should be concentrated along outside wall or other areas of greatest heat loss; spaced to set up a generally circular air movement, each heater supporting the air stream of the other. Additional vertical down flow unit heaters with appropriate accessory diffusers can be located to counteract ceiling heat losses (see Figure 1 Location charts).

## GENERAL SAFETY INFORMATION.

The heaters should be installed in accordance with the latest edition of (BS7671:2008) Requirements for Electrical Installation

To avoid possible electrical shock, be sure the electrical current is turned off at the main switch prior to wiring or servicing of unit.

If the power disconnect is not integral and is out of sight, lock it in the open position and tag to prevent unexpected application of power prior to performing any service or maintenance of the unit.

Make certain that the power source conforms to the requirement of your equipment.

Check heater voltage and phase on rating label to confirm that it matches the electric service supply

Wiring diagrams of the heater and supply connections are permanently attached to the inside of the heater access door. All terminals are coded in accordance with the wiring diagram. Accessory wiring is shown on the unit wiring diagram and supporting literature.

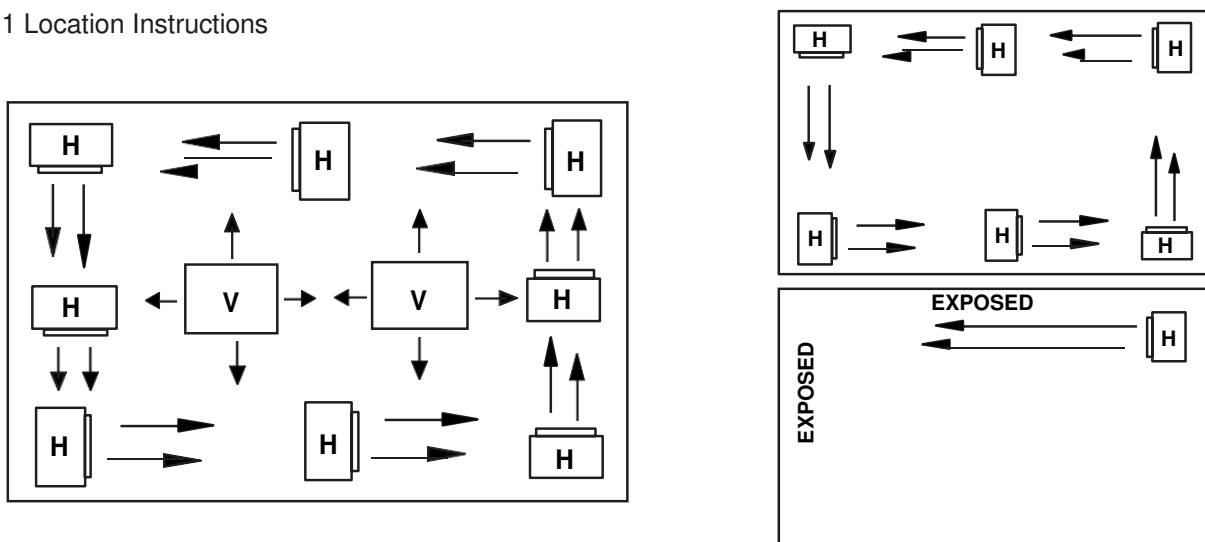
The heater must be mounted at least 2.2 metres above the floor to prevent accidental contact with the fan blade which could cause injury. Install unit so there are no obstructions to the intake or discharge. Maintain clearances as shown on Fig.1 & 2.

The wall/ceiling mounting structure and anchoring provisions must be of sufficient strength to support the combined weight of the heater and mounting bracket.

## CONTROL

On/off control of the heater and controls such as time clocks must be connected to the control circuit not the main supply. This is to allow the fan run on device to operate when the heater has been switched off. The heater must **NOT** be switched by breaking the main supply

Figure 1 Location Instructions



## PRINCIPLES OF OPERATION

Upon a call for heat from the remote low level or optional unit mounted thermostat, the unit fan motor and heating elements will be energized and remain ON until temperature reaches setting of thermostat; at which time the heating elements will be de-energized.

The fan motor will continue to run and purge the heater casing of residual heat until the setting of fan override is reached, then the fan motor will be de-energized.

For those units with a factory installed two speed fan switch, the unit as shipped from the factory is set to low speed. Customer option to set to high speed. For those units available with subdivided circuits, the optional two stage thermostat will, upon a call for heat, energize fan motor and the first stage heating element. Should temperature continue to fall, the thermostat will energize the second stage heating element.

Upon a rise in temperature towards the setting of the thermostat, the two stages of heating elements shall be de-energized in reverse sequence.

The fan motor shall continue to run and purge the heater casing of residual heat until setting of fan override is reached, then the fan motor will be de-energized.

The optional unit mounted de-stratification thermostat will energize the unit heater fan motor upon a rise in temperature above its setting.

When the unit mounted stratification thermostat closes on a temperature rise and at the same time the floor thermostat calls for heat, the motor will be energized immediately and the heating element will be energized, as previously described.

The automatic reset safety high limit shall de-energize the heating elements **and control circuits** should the temperature exceed the setting of this device. The fan safety override will energize the fan motor any time the setting of this device is exceeded so as to purge heater casing of excess residual heat.

When the fan switch is placed in the ON position (for summer air circulation), the unit heater fan motor will be energized.

**NOTE:**The wall thermostat should be set to the OFF position during this mode of operation (units with contactors).

For thermostats equipped with an integral fan switch, place the switch in the HEAT or AUTO position for operation of the fan and elements which will then be under control of the thermostat as described above.

When switch is placed in the OFF position, the unit will be de-energized. When switch is placed in the FAN position, elements shall be de-energized and fan shall be immediately energized.

## SPECIFICATION

Cat No	Heater				Fan motor		Air Vol	Max Mtg Ht (m)		Throw	Wt
	kW	Volts	Phase	Amp/ph	Watt	rpm	m3/hr	Horiz	Vert	m	kgs
CUH-03-1	3.3	230	1P	13.4	6.0	1550	680	2.8	2.8	3.7	12
CUH-03-3C	3.3	400	3P&N	4.5	6.0	1550	680	2.8	2.8	3.7	12
CUH-05-1	5.0	230	1P	20.5	6.0	1550	680	2.8	2.8	3.7	12
CUH-05-3C	5.0	400	3P&N	6.8	6.0	1550	680	2.8	2.8	3.7	12
CUH-07-3C	7.5	400	3P&N	10.2	15.0	1550	1190	3.0	3.7	6.7	23
CUH-10-3C	10.0	400	3P&N	13.6	15.0	1550	1190	3.0	4.3	6.7	23
CUH-15-3C	15.0	400	3P&N	20.4	38.0	1550	1870	3.4	6.1	9.8	30
CUH-20-3C	20.0	400	3P&N	27.2	62.0	1550	3400	3.7	5.5	9.8	55
CUH-25-3C	25.0	400	3P&N	34.0	62.0	1550	3400	3.7	6.7	13.7	55
CUH-30-3C	30.0	400	3P&N	40.8	62.0	1550	3400	3.7	6.1	12.2	55
CUH-40-3C	40.0	400	3P&N	54.4	186.0	1550	5200	3.7	7.3	16.7	

# INSTALLATION INSTRUCTIONS

## CUH HEAVY DUTY UNIT HEATER

All electric unit heaters are shipped fully assembled. Installation includes hanging the unit, wiring of optional control devices and electrical wiring to the unit.

To ensure proper delivery of the heated air to desired areas, follow the mounting height tables included in these instructions. See Fig. 1 & 2 for minimum wall and ceiling clearances.

Heaters may be mounted in the horizontal or vertical air discharge configuration using factory supplied mounting equipment or using special hardware facilities supplied by others.

The wall and/or ceiling structure must be sufficient to support the combined weight of the heater and any mounting bracket and accessories.

Be sure power source is de-energized before installing heater. The power supply must incorporate a means of isolation having a contact separation of at least 3mm in all poles. Check heater voltage and phase listed on rating plate to make sure they are the same as the electrical service supplied.

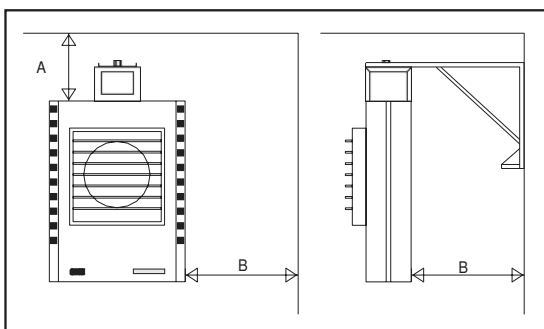
Open the access panel and remove the desired knock-out(s) on back of the unit.

Install any optional accessories following their installation instructions before mounting unit. Following the correct unit/accessory wiring diagram, connect the power supply electrical ground and accessories to the correct terminals or termination points using accepted practices.

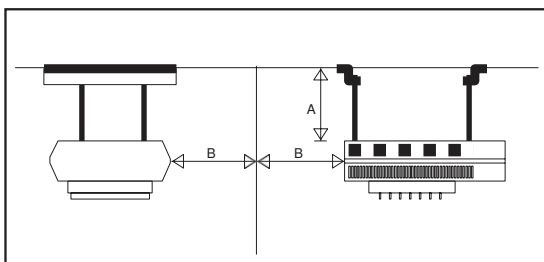
**WARNING:- THE HEATER MUST BE EARTHED**

After the installation is complete, replace the access panel. Set the controls (thermostat, switch, etc) at their desired control point and apply power to the unit. Check correct operation.

**FIG 1 HORIZONTAL DISCHARGE**

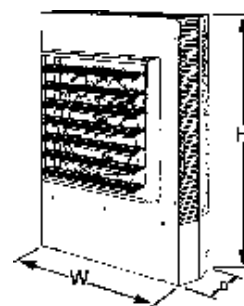


**FIG 2 VERTICAL DISCHARGE**

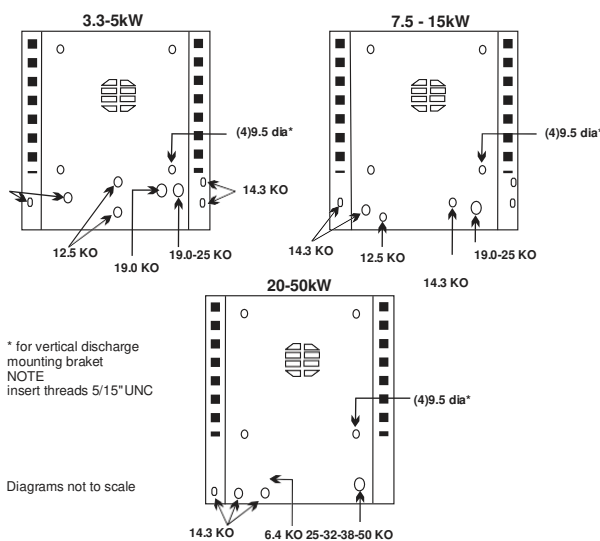


Airflow	Heater	Bracket	A mm	B mm
Horizontal	03 - 05	C35	300	300
	07 - 20	C720	450	600
	25 - 30	C2550	450	600
Vertical	03 - 05	VB35	300	300
	07 - 20	VB720	450	600
	25 - 30	V2550	450	600

### DIMENSIONS



DIMENSIONS (mm)			
KW	H	W	D
3.3 - 5.0	450	368	165
7.5 - 10.0	620	546	165
15.0 - 20.0	730	546	165
25.0 - 40.0	865	743	256



# INSTALLATION INSTRUCTIONS

## TASKMASTER -- 5100 SERIES UNIT HEATER (part 2)

### HORIZONTAL-- AIR DISCHARGE MOUNTING

CUH -C35, C720 and C2550 brackets

Swivel hanger brackets may be used to suspend unit heaters from either the wall (figure 5) or the ceiling (figure 6). Attach hanger base (A) to top of heater with the four 5/16 X 18 caps screws and lockwashers provided.

Attach main hanger frame (B) to wall or ceiling in desired location using suitable attachments (supplied by others).

Lift heater into position inserting stud (D) through hole in main hanger frame and attach lock nut provided (E) tightening to within two turns of being tight.

Swivel heater to desired position, tighten lock nut.

Figure 5  
WALL MOUNT  
HORIZONTAL DISCHARGE

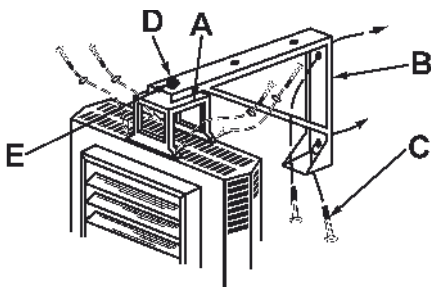
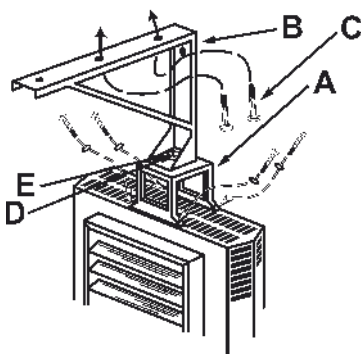


Figure 6  
CEILING MOUNT  
HORIZONTAL DISCHARGE



### SAFETY

The correct procedures for working at height must be adopted when installing this heater.

CUH07 and larger units weigh over 20kgs and care should be taken with their handling.

The heater must be installed by a suitably qualified person in accordance with current regulations.

### VERTICAL--AIRDISCHARGEMOUNTING

CUH -VB35 and VB720 brackets

Securely fix bracket rails to ceiling or structure at desired height and location.  
- refer to table for min / max dimensions and weights.

The brackets are easiest to install with the heater mounting holes outermost, thus allowing tightening of the locknuts. They can be mounted the other way if this allows a more secure fixing.

CUH 03 and 05 - The bracket rails can be mounted to the unit either horizontally or vertically with fixing hole centres 334mm or 253mm respectively.

CUH 07 and 10 - The bracket rails should be mounted horizontally with fixing hole centres 458mm.

CUH 15 and 20 - The bracket rails should be mounted horizontally with fixing hole centres 570mm

Assemble mounting studs, nuts and spring washers to the four threaded inserts in rear of heater ensuring the studs do not protrude more than 10mm inside the case. Tighten nut against heater.

Run second nuts approx 25mm down studs, put on plain washers.

Locate studs in holes in bracket rails and secure with plain washers, spring washers and nuts.

Adjust nuts to squarely locate heater without distorting the heater body.

Ensure all nuts are tight and fixings secure.

CUH 25-40 - The CUH -V2550 bracket should be used  
- see instructions with bracket kit

NOTE: When mounting heater using 5/16" UNC all thread rod (by others) do not screw the rod more than 10mm beyond the inside of the case.

## 5100 SERIES UNIT HEATER TROUBLE SHOOTING GUIDE

SYMPTOM	POSSIBLE CAUSE(S)	CORRECTIVE ACTION
Thermostat calls for heat, but heater does not function.	1. Open (blown) fuse  2. INCORRECT WIRING  3. Thermal cut-out open, de-energizing heater element and control circuit.	1. Replace fuses, check for cause. (see Replacement Parts List for fuse size)  2. CHECK WIRING CONNECTIONS  3. Check for the following: --- Correct supply volts and phase --- Correct control wiring (heater control must be thru thermostat control wiring section only). --- Power interruption to heater during heater operation. --- Restriction of air around heater 1-5 minute fan purge after thermostat off
Fan motor runs HOT	1. Dust accumulation or excessive dirt on motor  2. Dirt accumulation  3. Motor needs lubrication.	1. Clean fan motor and casing of grease and oil accumulation.  2. Clean louvers and between heating elements.  3. See Maintenance.
Fan motor runs, but no heat.	1. Element contactor not operating correctly  2. Element fuse blown (if fitted).	1. Check wiring for open circuit. Replace contactor if defective  2. Replace fuses, check for cause.

### MAINTENANCE

**CAUTION:** Make certain that the power source is disconnected before attempting to service or disassemble any component. If the power disconnect is out of the line of sight, lock it in the OPEN position and tag to prevent the application of power.

### ELECTRICAL

Once a year inspect the control panel wiring to make certain insulation is intact and all connections are tight. Inspect all heater and relay contacts. If the contacts appear badly pitted or burned, replace the contactor / relay

### CLEANING

Clean the unit casing, fan and motor once a year A dirty motor will tend to run hot and eventually will be damaged. internally. Any rust spots on the casing should be cleaned and repainted.

### LUBRICATION

All units up to 15KW have fan motors that are permanently lubricated so that only occasional cleaning is required. Units above 15 KW have fan motors lubricated for 5 years of continuous duty of 10 years of intermittent operations. When required, remove the oil access on plug back of heater at motor intake grill, open oil cap, fill with S.A.E. No.10 electric motor oil, replace plugs and access plug.

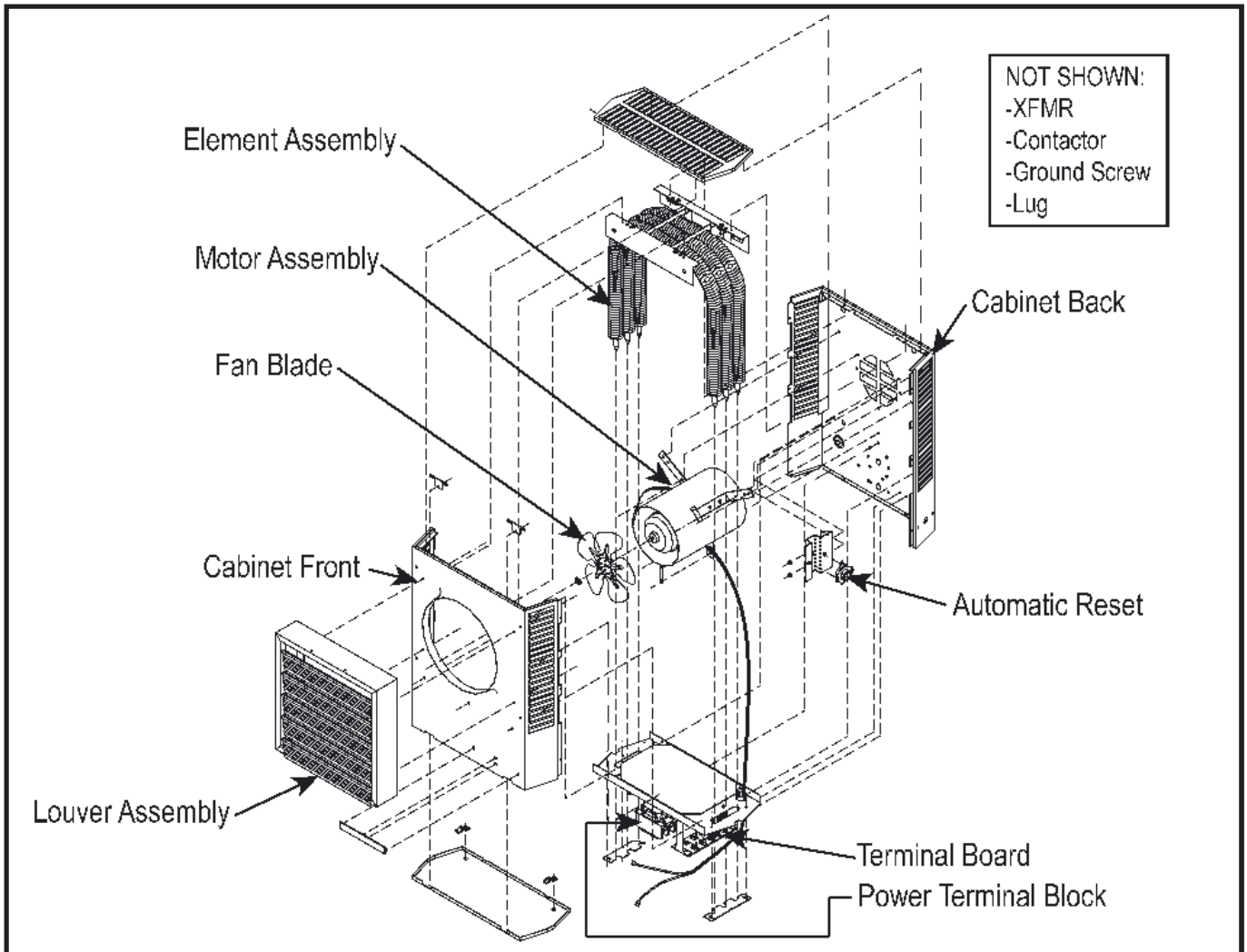
## CUH HEAVY DUTY UNIT HEATER PARTS LIST - PART NUMBERS

HEATER MODEL	MOTOR	ELEMENT ASSEMBLY	AUTOMATIC RESET CUT-OUT	FAN OVERRIDE	XFMR	CONTACTOR	POWER TERMINAL BLOCK
CUH-03-1	D010-01 56562-017	B018-01 60715-002	E036 57640-006	E035 56811-001			F043 56815-001
CUH-03-3C	D01-01 56562-017	B018-01 60715-002	E036 57640-006	E035 56811-001		E023 50378-240	2 x F043 2 x 56815-001
CUH-05-1	D010-01 56562-017	B019-01 60715-006	E036 57640-006	E035 56811-001			F043 56815-001
CUH-05-3C	D010-01 56562-017	B019-01 60715-006	E036 57640-006	E035 56811-001		E023 50378-240	2 x F043 2 x 56815-001
CUH-07-1C	D011-01 56823-012	B020-01 56954-006	E037 57640-003	E035 56811-001			F043 56815-001
CUH-07-3C	D011-01 56823-012	B020-01 56954-006	E037 57640-003	E035 56811-001		E023 50378-240	2 x F043 2 x 56815-001
CUH-10-3C	D011-01 1 56823-012	B021-01 56953-004	E037 57640-003	E035 56811-001		E023 50378-240	2 x F043 2 x 56815-001
CUH-15-3C	D012-01 56825-002	B022-01 56954-010	E038 57640-004	E035 56811-001		E023 50378-240	2 x F043 2 x 56815-001
CUH-20-3C(#4)	D012-01 56825-002	B022-01 56954-010	E038 57640-004	E035 56811-001		E023 50378-240	2 x F043 2 x 56815-001
CUH-25-3C	D016-01 56943-002	B048-01 56954-018	E058 57640-005	E044 56811-002	E098 60719-009	E040 58027-058	2 x F043 2 x 56815-001
CUH-30-3C	D016-01 56943-002	B049-01 56954-021	E058 57640-005	E044 56811-002	E098 60719-009	E040 58027-058	2 x F043 2 x 56815-001
CUH-40-3C	D016-01 56945-002	B050-01 56954-024	E058 57640-005	E044 56811-002	E098 60719-009	E040 58027-058	2 x F043 2 x 56815-001

KW	FAN BLADE	TERMINAL BOARD	GROUND CONN.	MOTOR CAPACITOR	LOUVRE
3.3 - 5	C007 56806-001	56809-001 56809-001	1458	-	(5) A035 (5) 56986-001
7.5 - 10	C003 50551-002	56809-001 56809-001	1458	-	(7) A036 (7) 56986-003
15 - 20	C004 56813-001	56809-001 56809-001	1458	-	(7) A036 (7) 56986-003
25 - 30	C005 57114-001	56809-001 56809-001	3981	E054 57100-001	(9) A037 (9) 56987-001
40	C006 57115-001	56809-001 56809-001	3981	E054 57100-001	(9) A037 (9) 56987-001

CONTROL CIRCUIT	FUSE HOLDER	FUSE (3A)
All sizes	E091	E092

# CUH HEAVY DUTY UNIT HEATER ASSEMBLY DRAWING



## WARRANTY

This product is guaranteed, in accordance with our Conditions of Sale, for a period of 12 months from date of purchase. We will repair or replace, at our discretion, any part found to be defective. We cannot accept responsibility for any consequential liability.

The warranty will be invalid if the heater has not been installed in accordance with these instructions. This does not affect your statutory rights.

The manufacturers reserve the right to change the specification at any time without prior notice E&O E

Turnbull & Scott  
Burnfoot Industrial Estate  
Hawick  
Roxburghshire  
TD9 8SL

Tel: 01450 372053  
E-mail: [info@turnbull-scott.co.uk](mailto:info@turnbull-scott.co.uk)  
Web: [www.turnbull-scott.co.uk](http://www.turnbull-scott.co.uk)

**Turnbull & Scott**<sup>™</sup>  
Trusted.